

Monteringsanvisning:

LAVTBYGGGENDE

FRONTMONTERT BESLAG



Har du spørsmål eller trenger du hjelp?
Ring Car-Bo Garasjeporter AS på 55 11 42 10

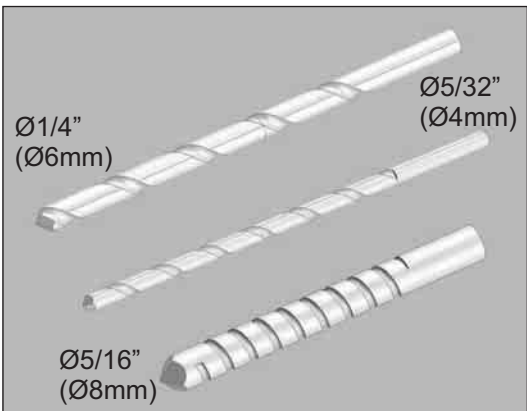
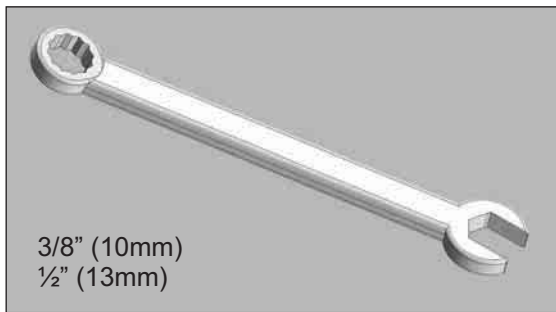
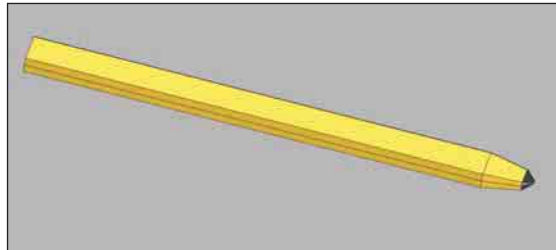
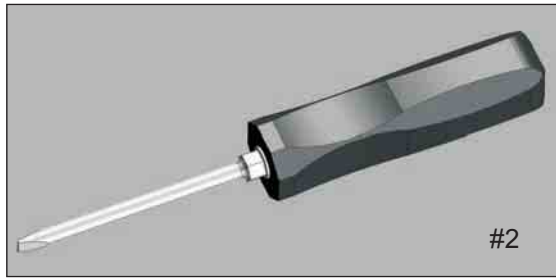
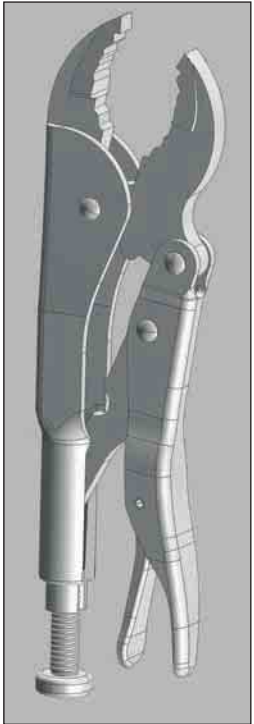
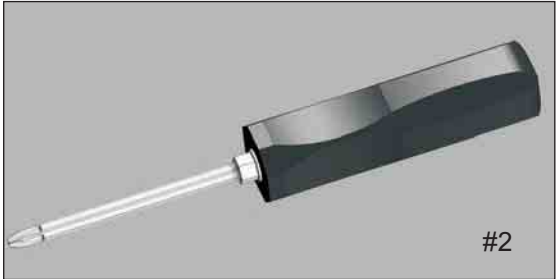
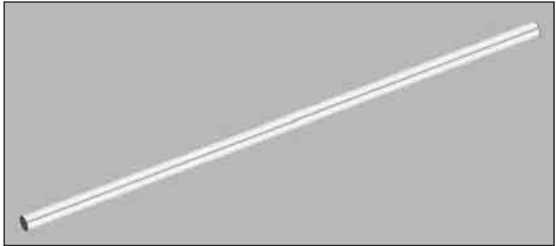
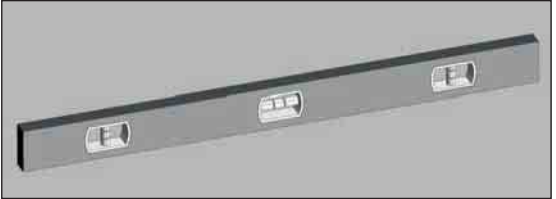
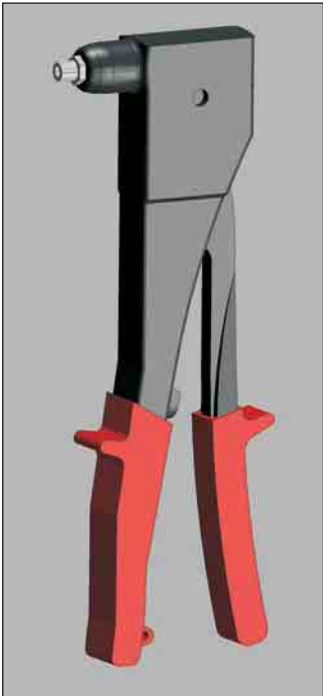
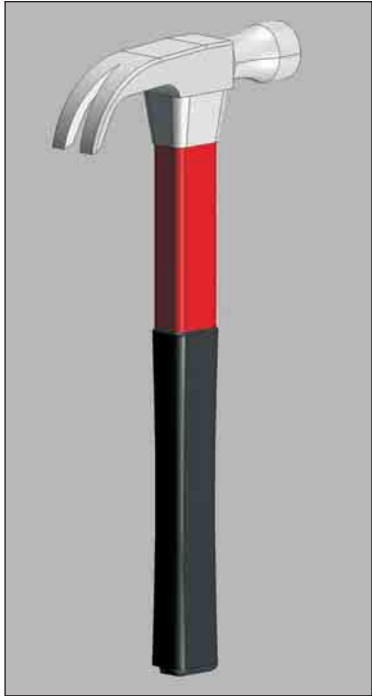
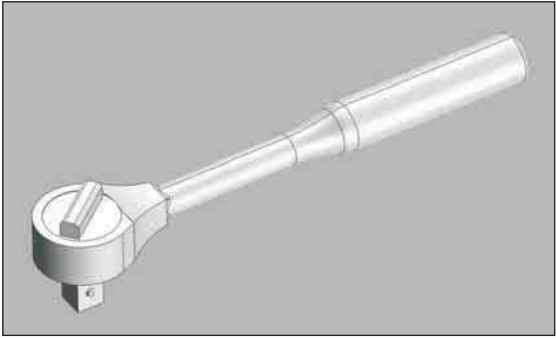
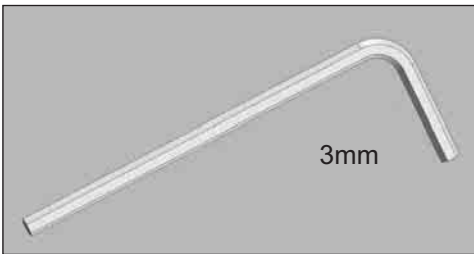

A

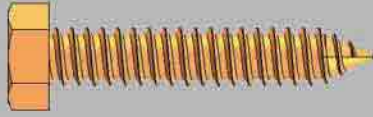
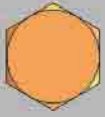

B

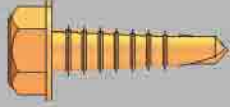

C

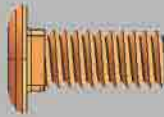
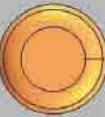

F



G



H



I



D

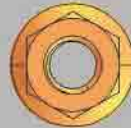

J



K



1

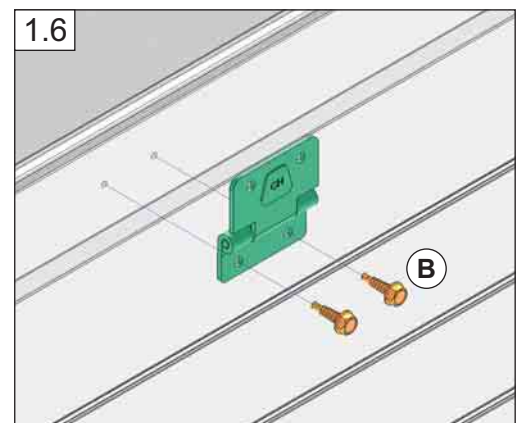
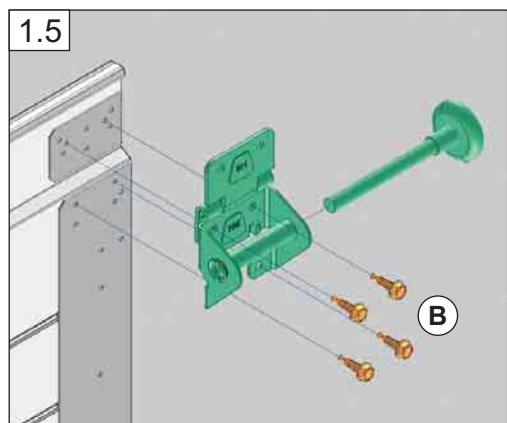
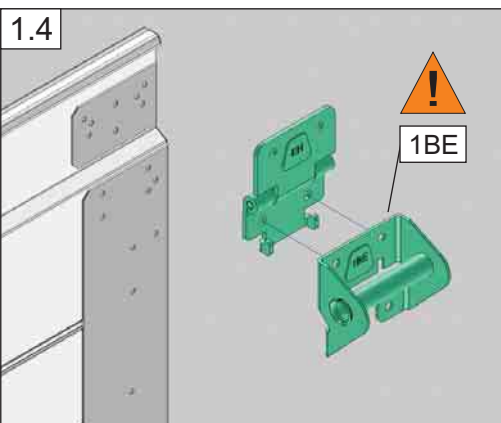
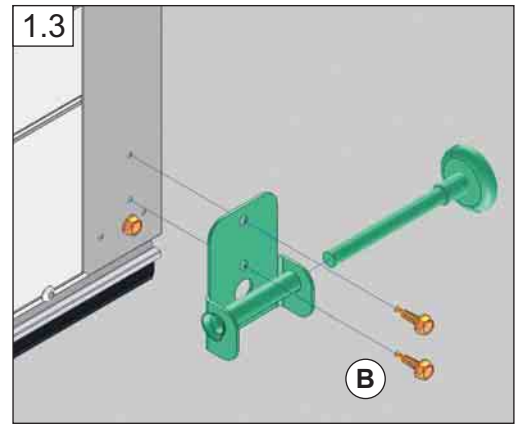
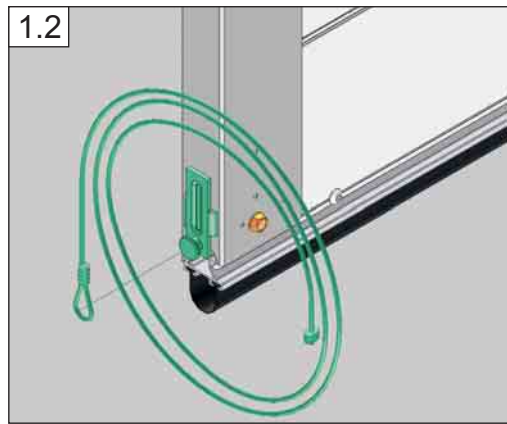
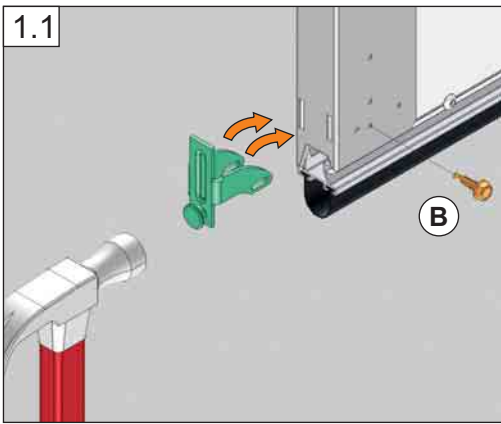
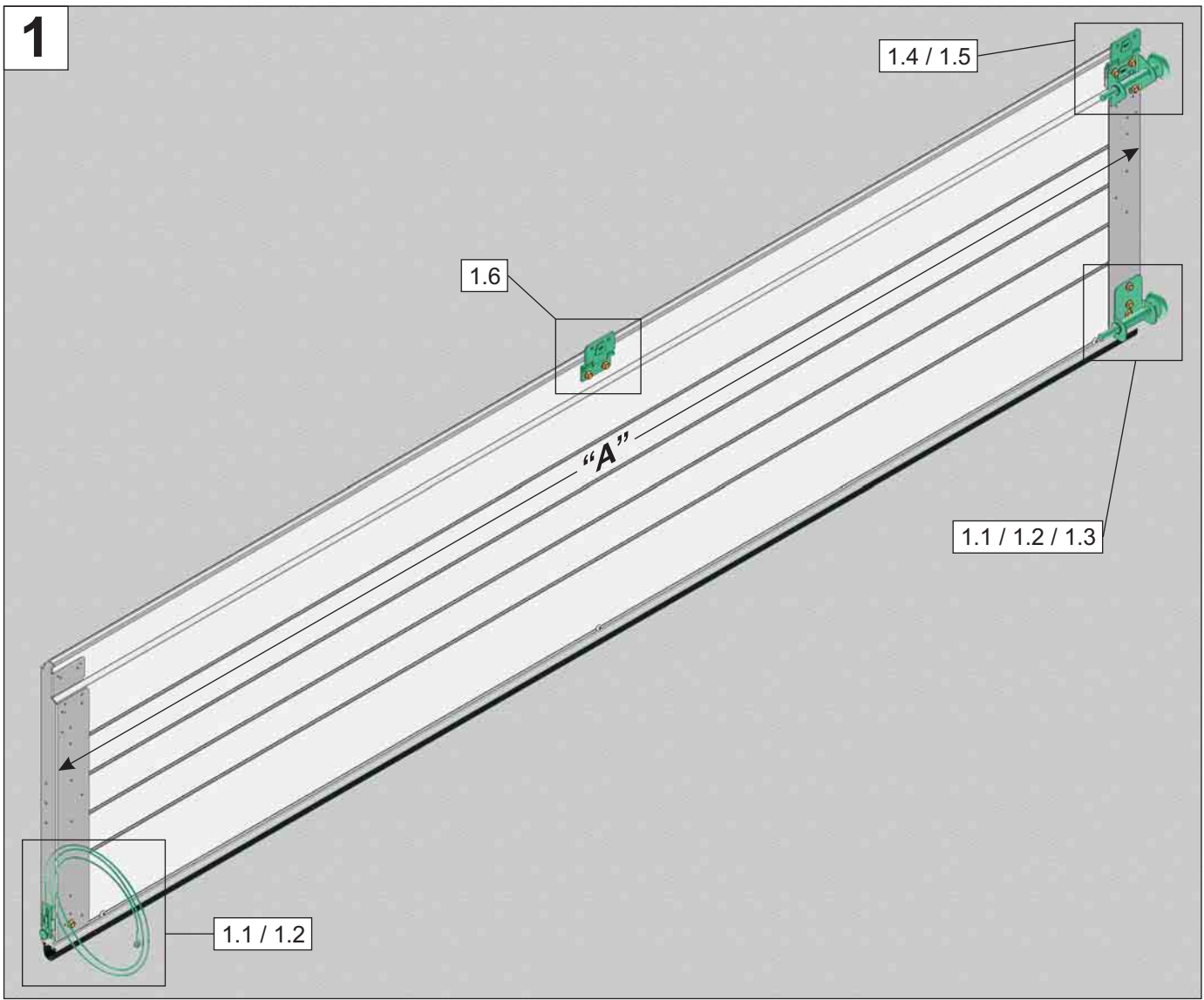

2

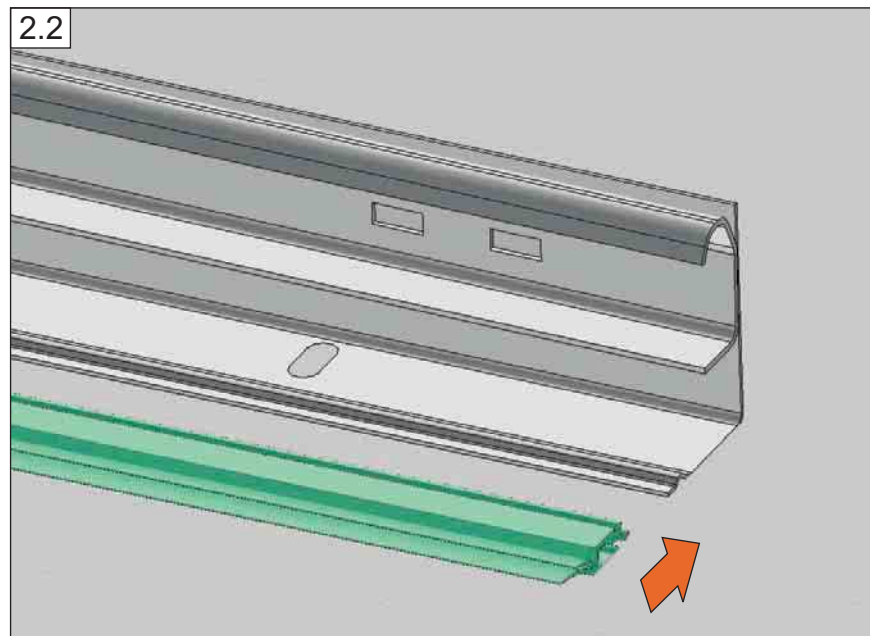
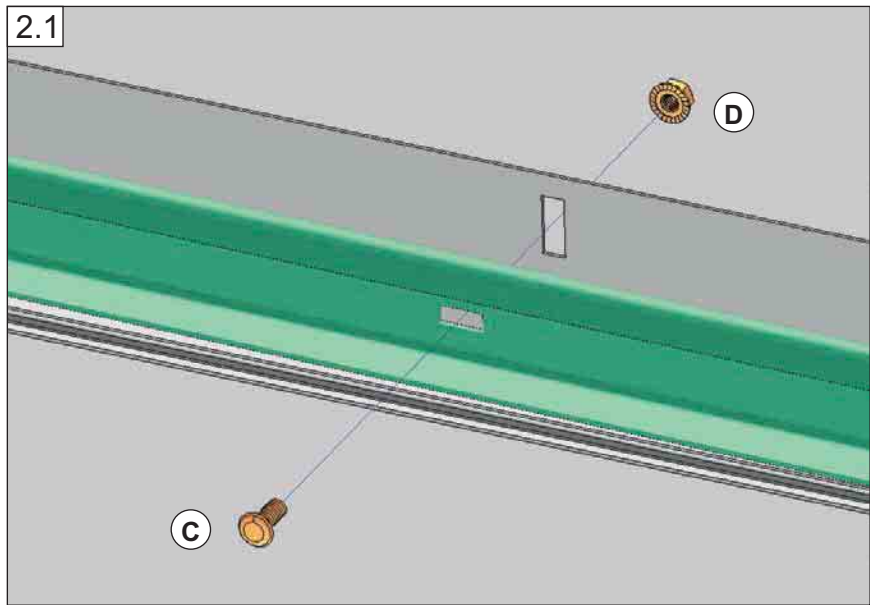
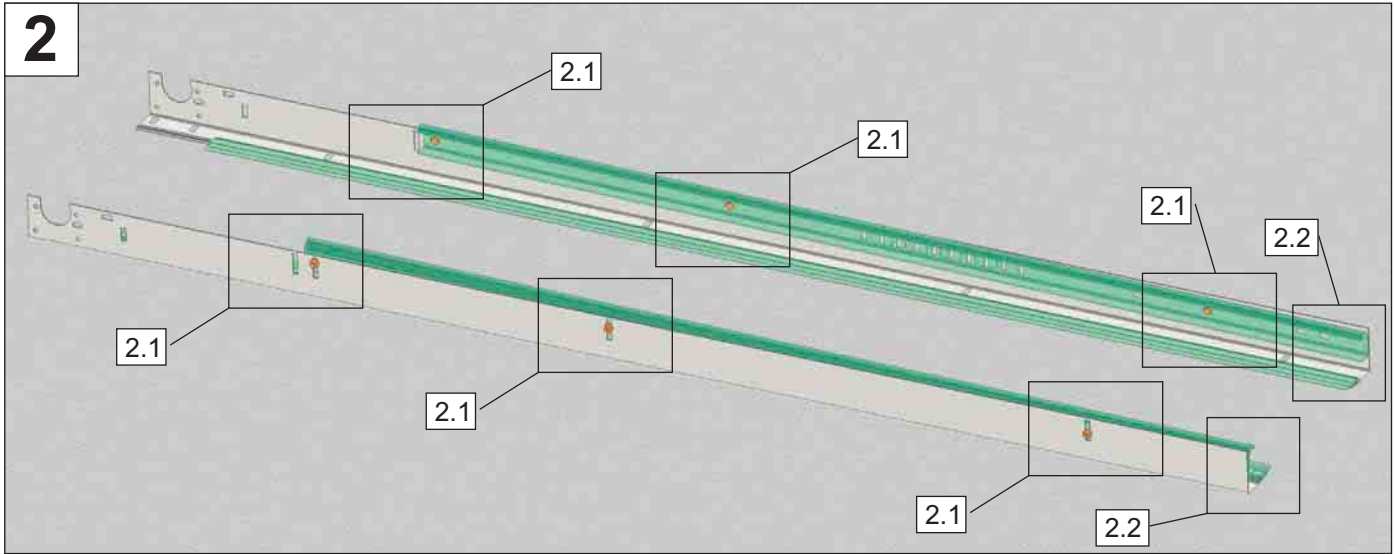

4

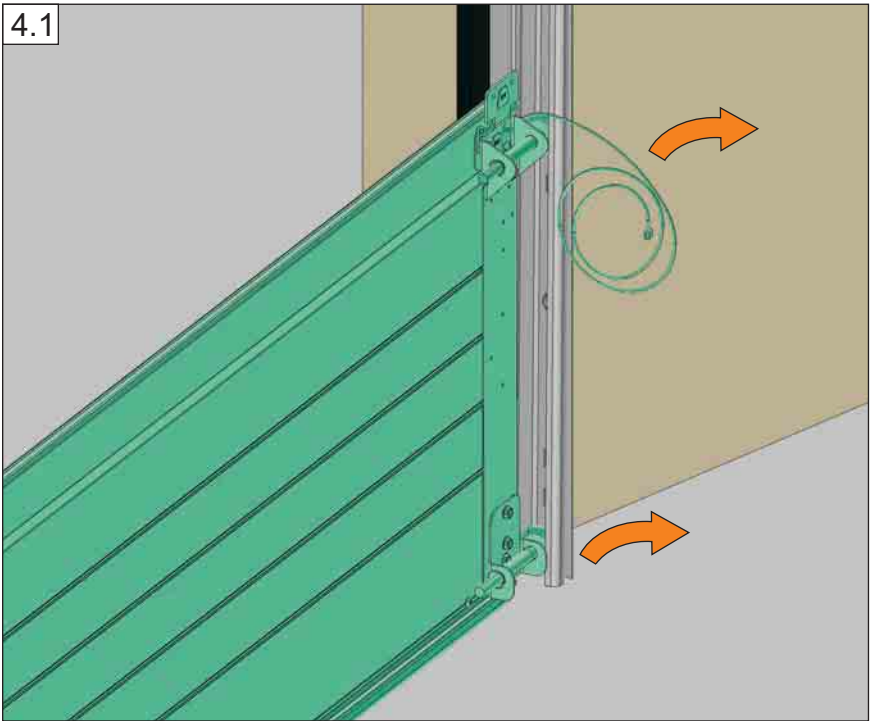
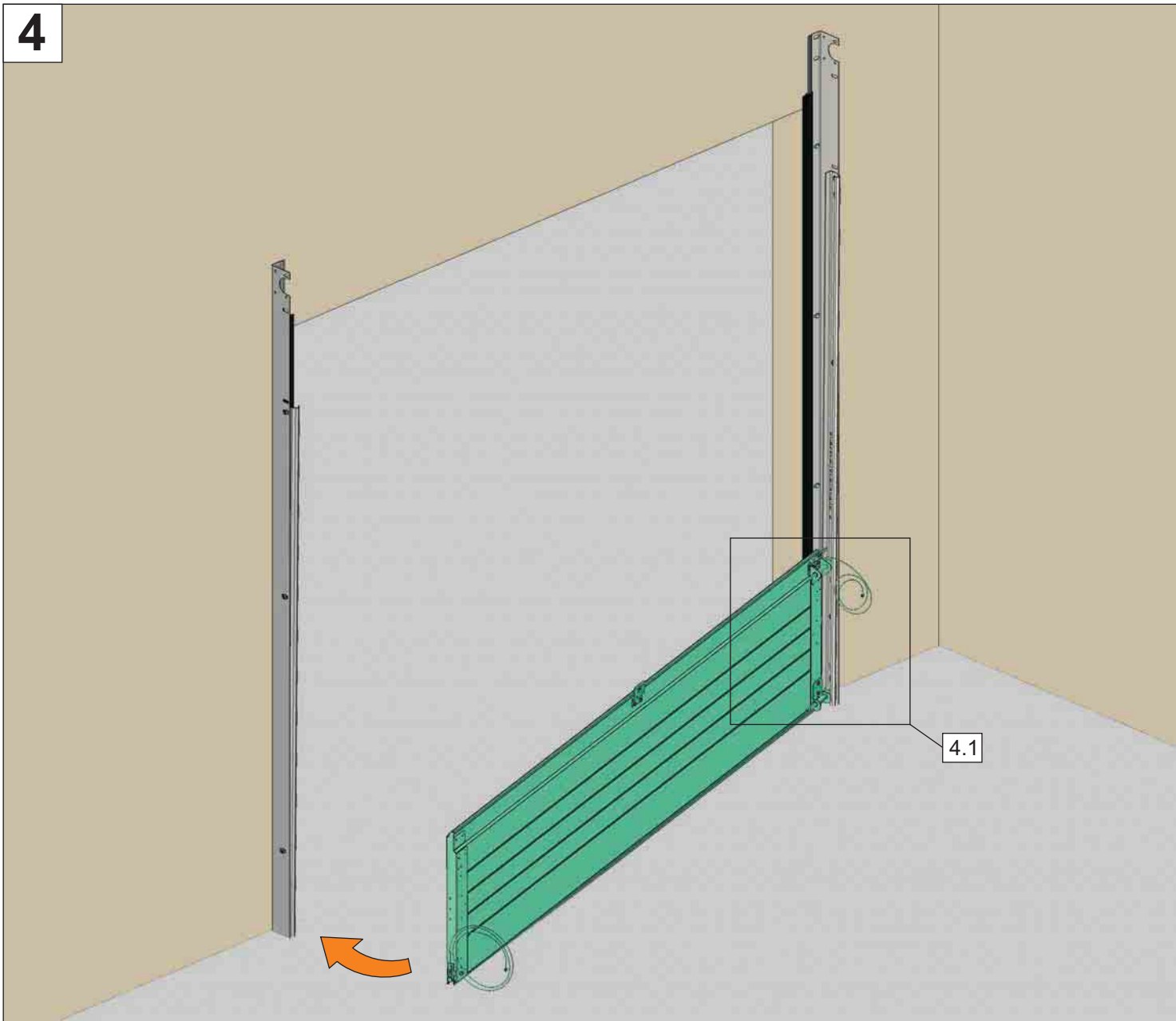

5

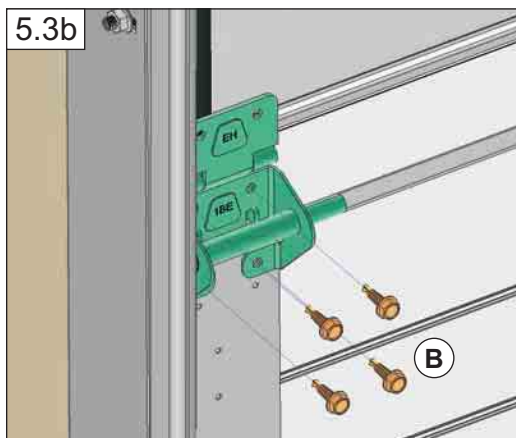
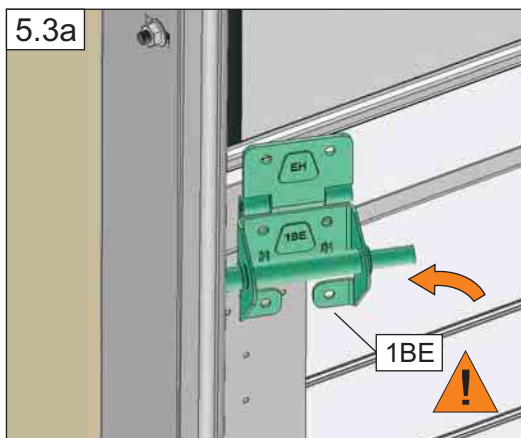
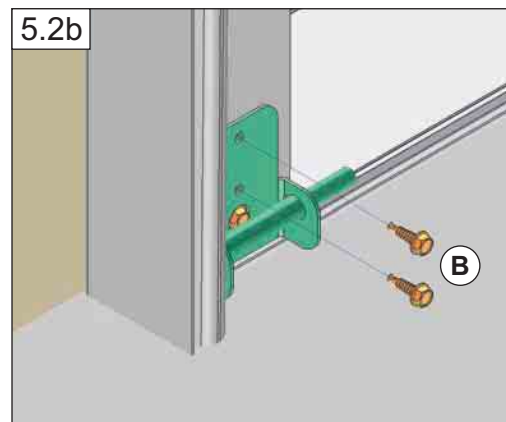
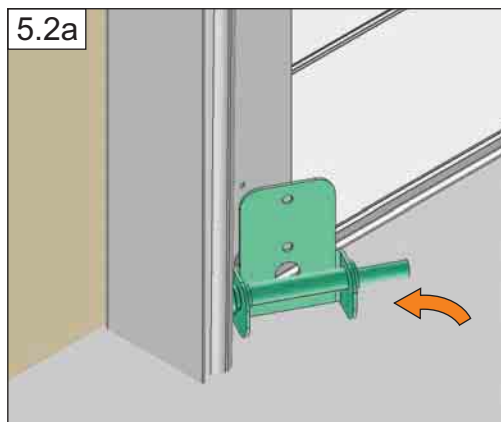
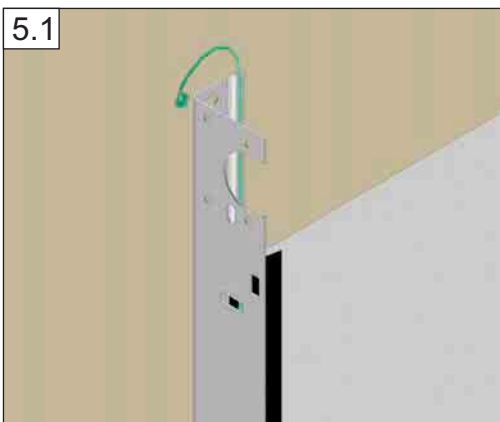
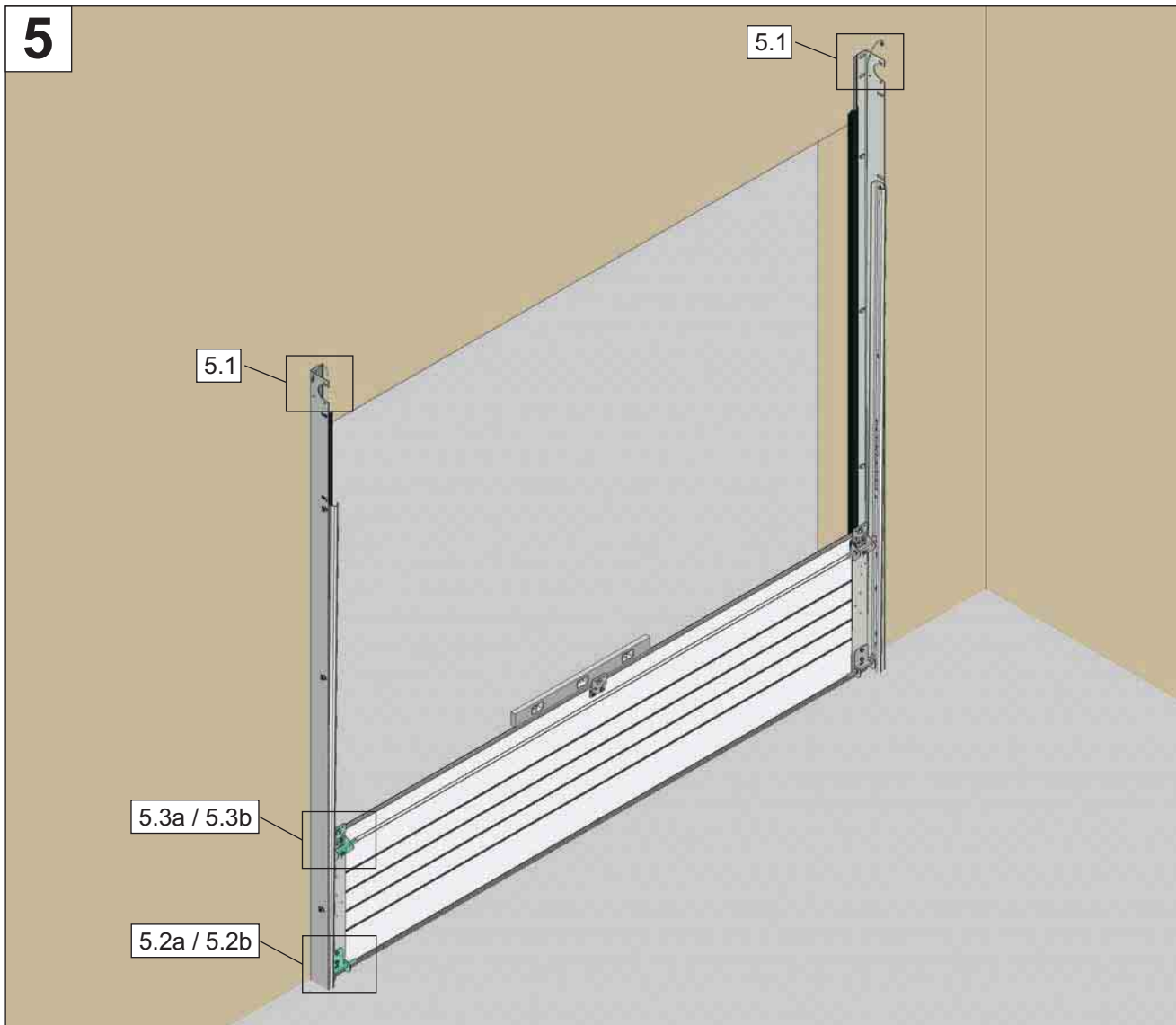

6

4978.5mm (16'-4") ≤ A ≤ 5486.5mm (18'-0")

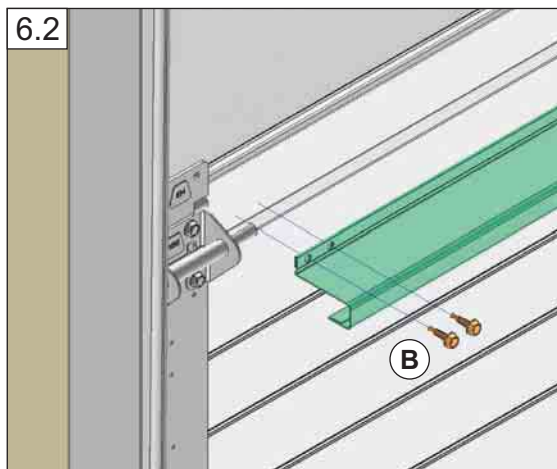
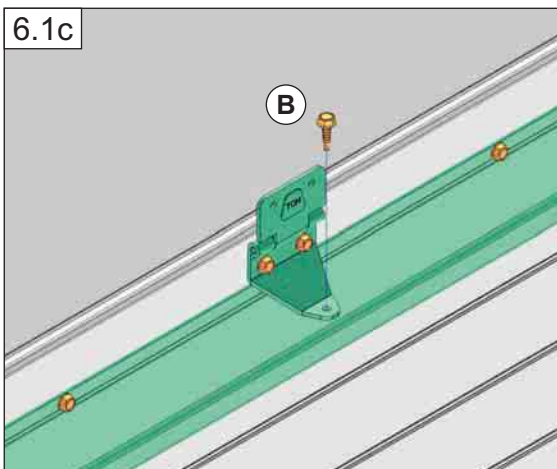
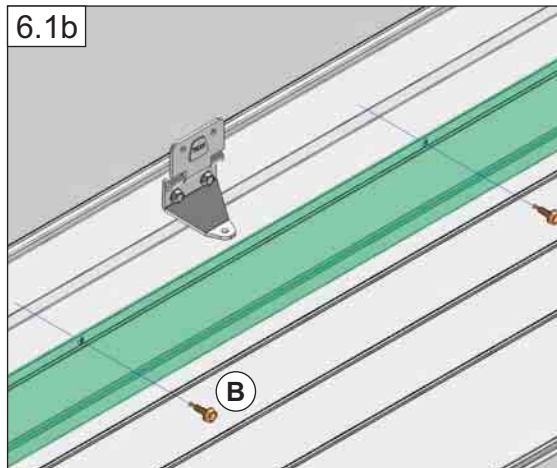
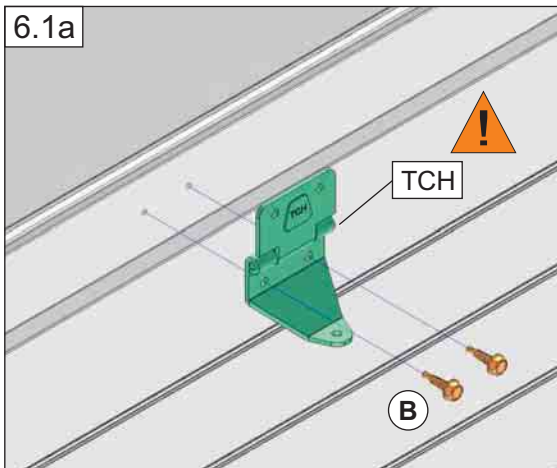
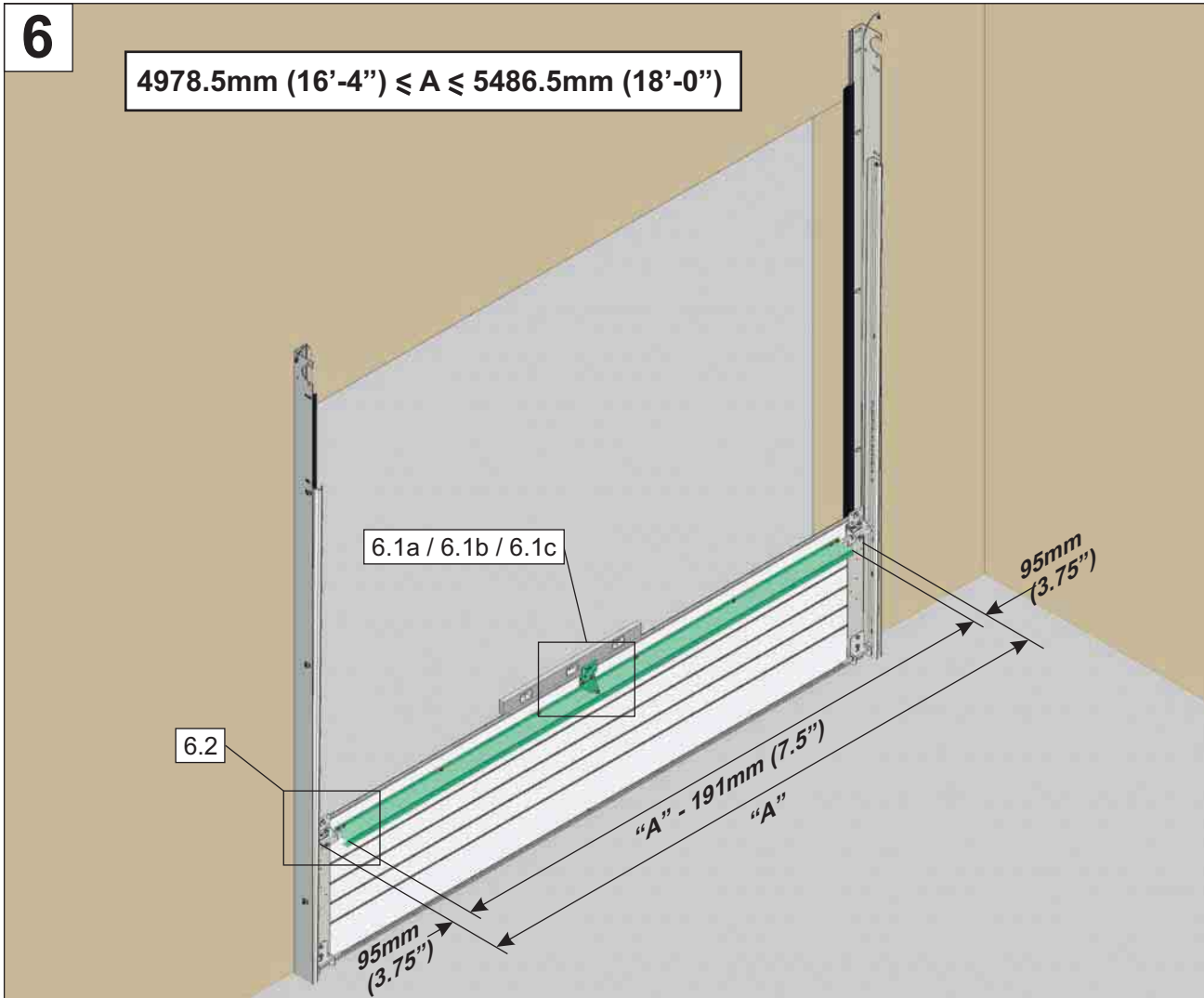

7

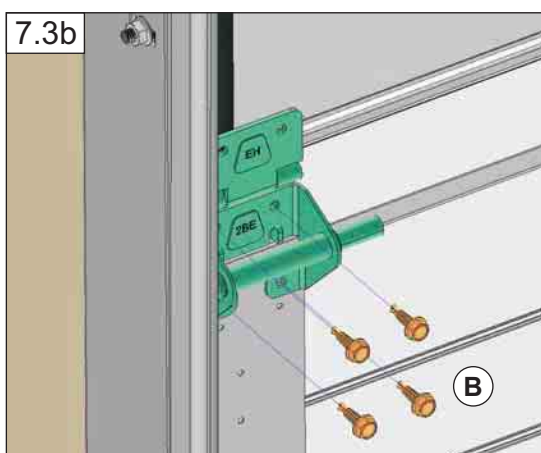
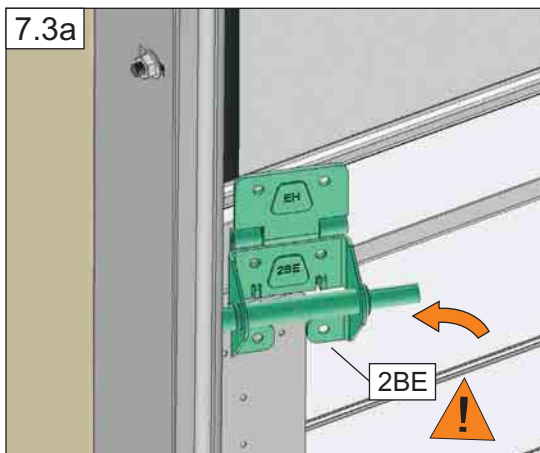
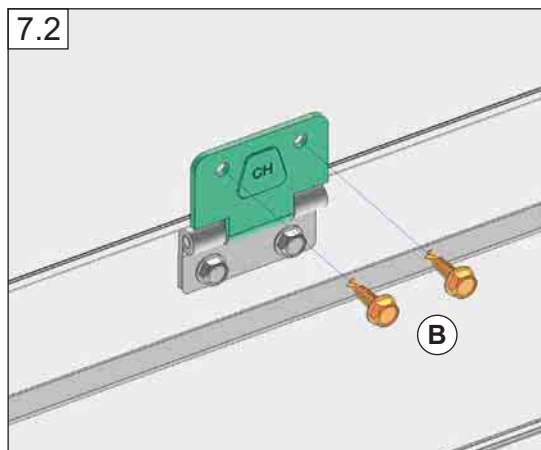
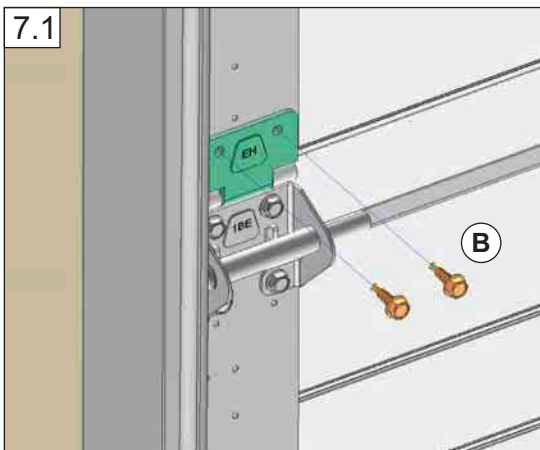
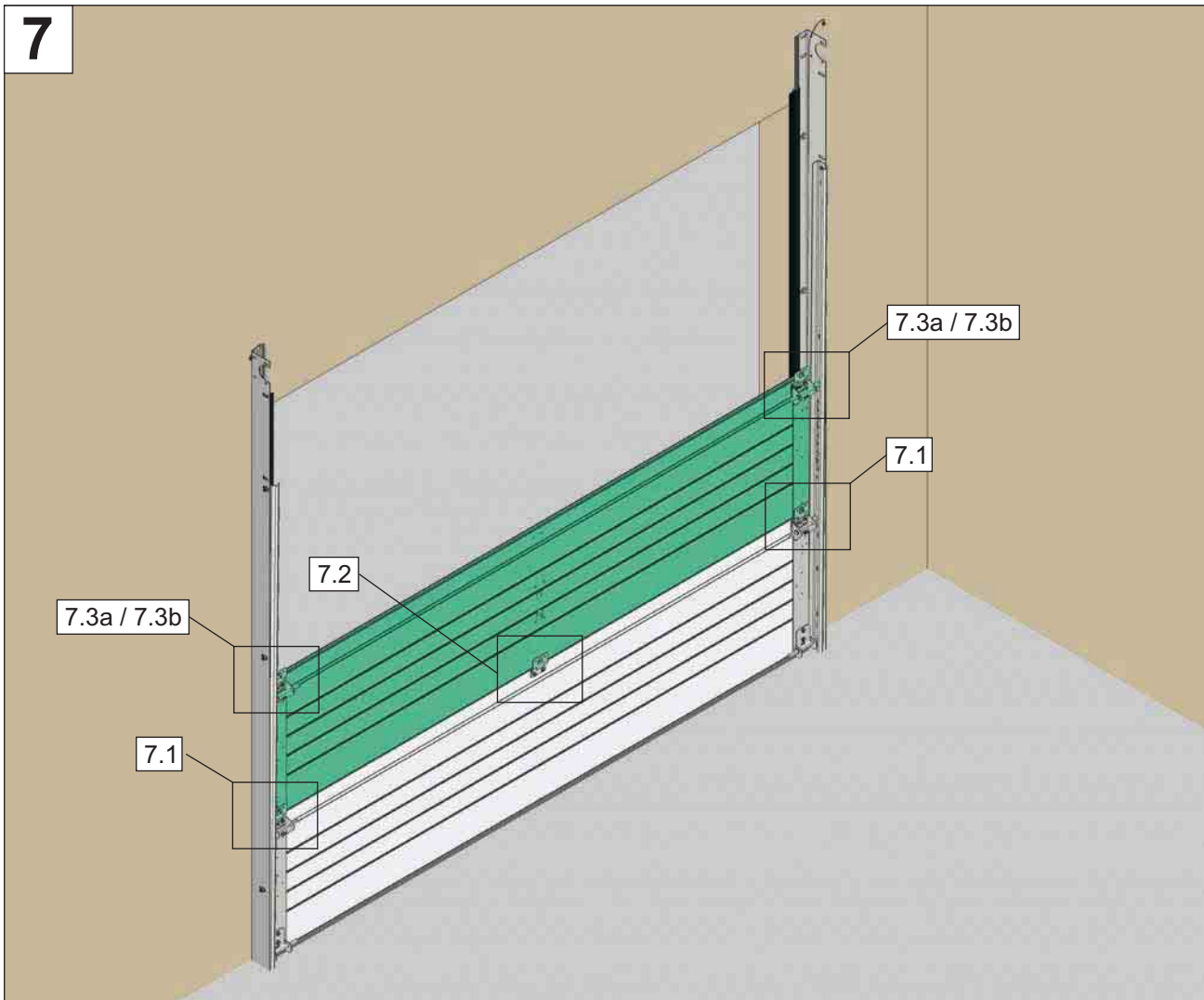

8

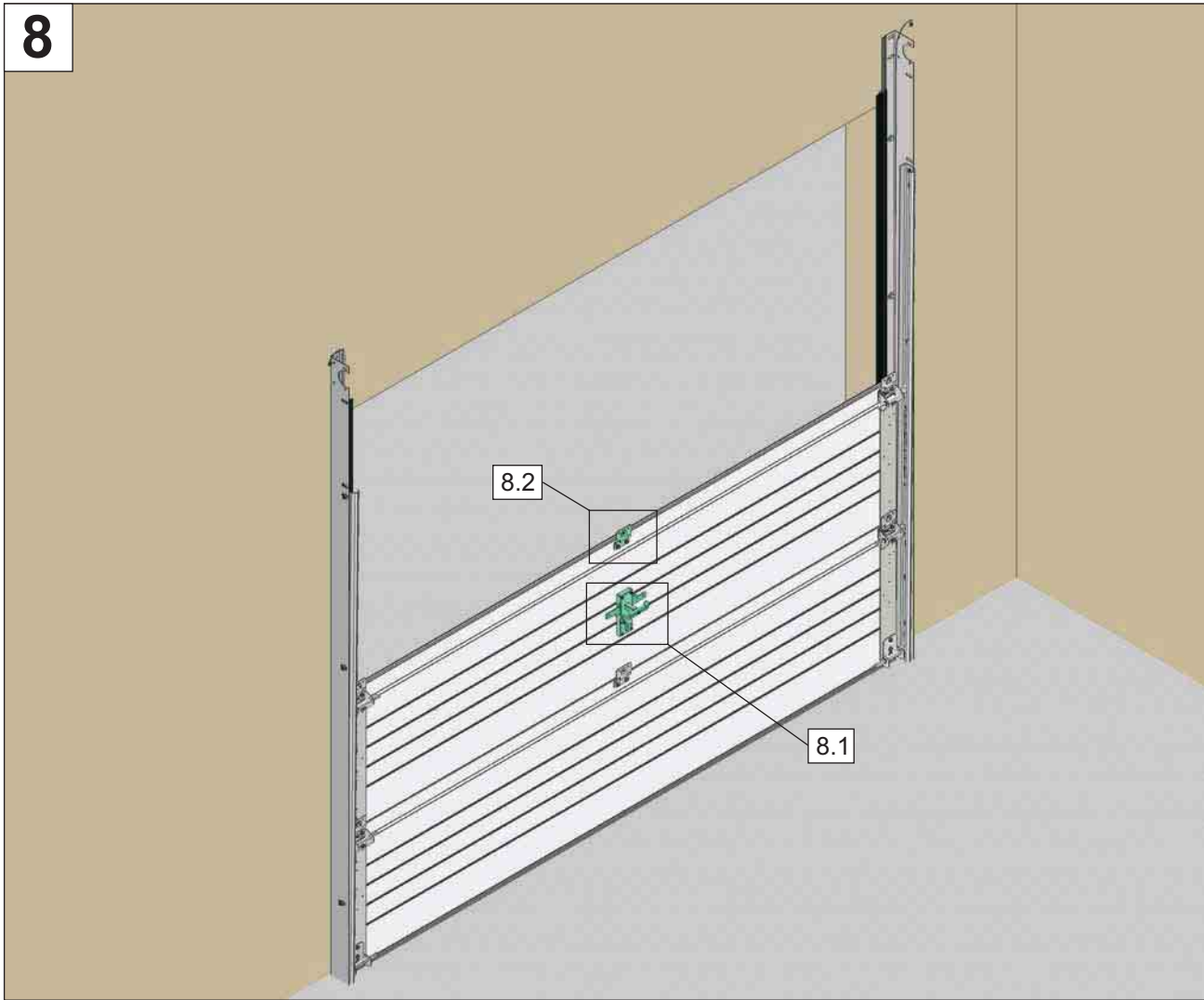

8.1

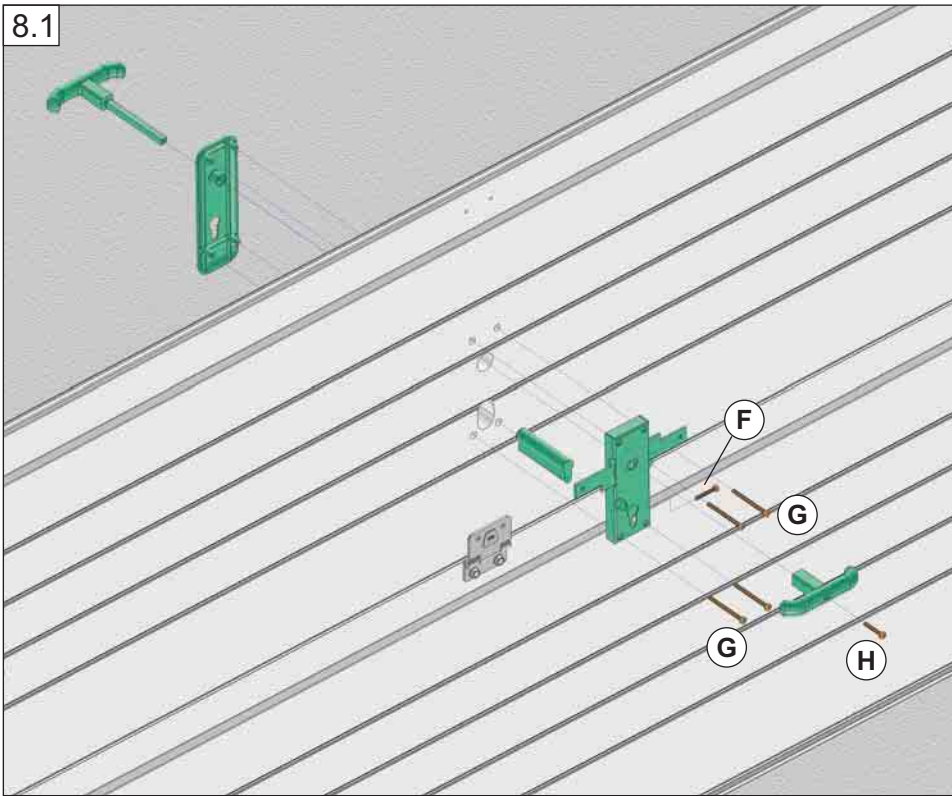

8.2

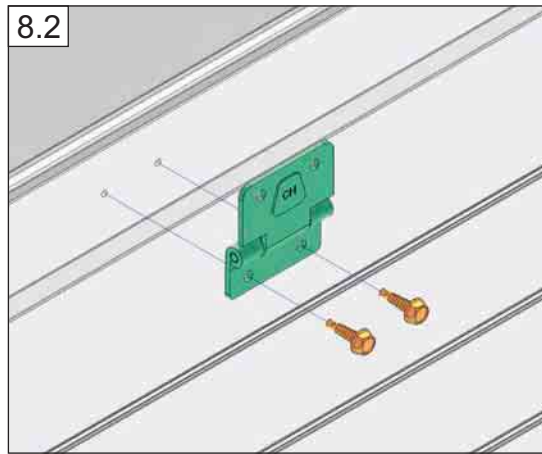

9

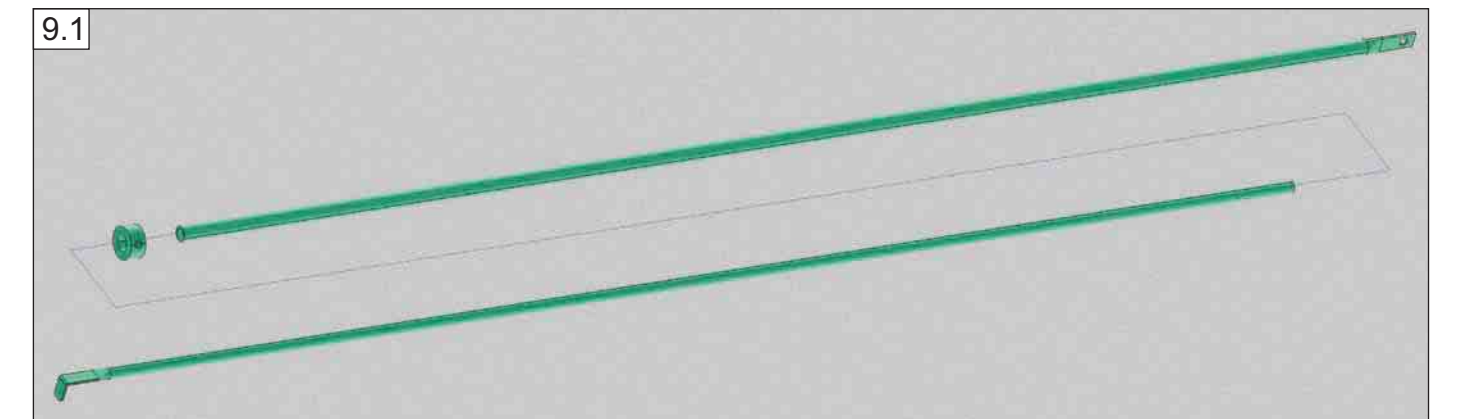
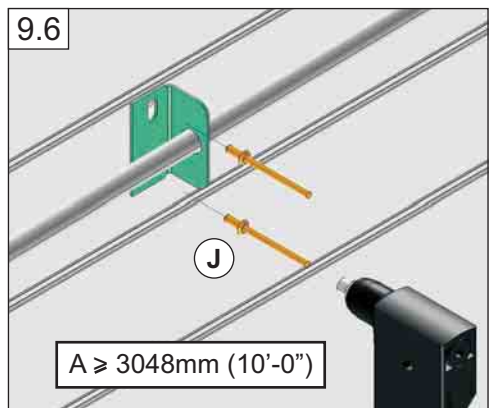
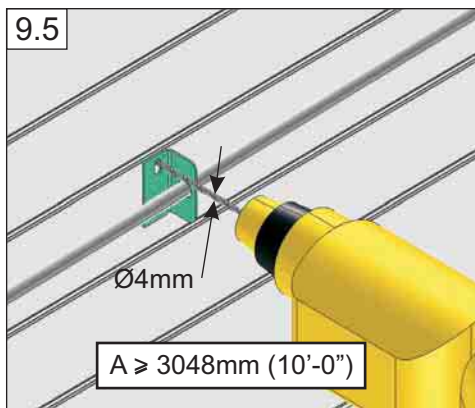
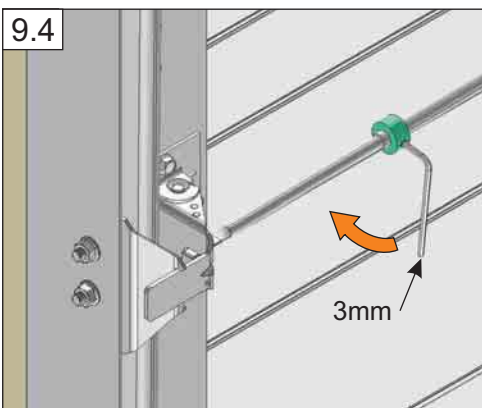
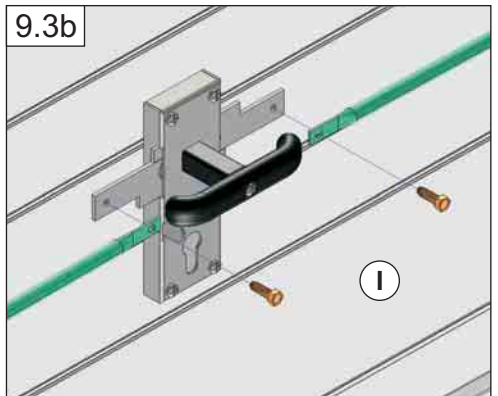
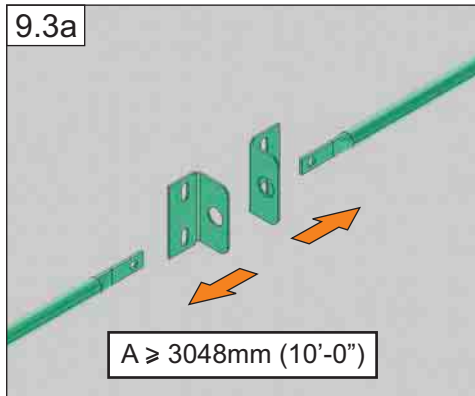
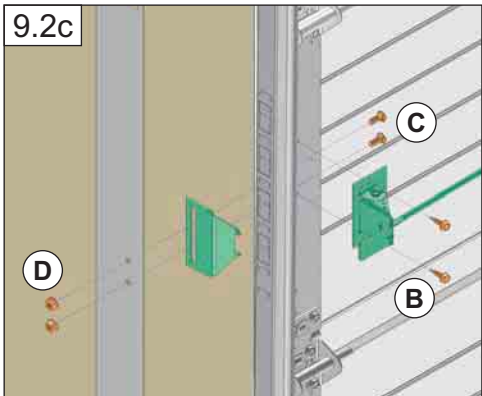
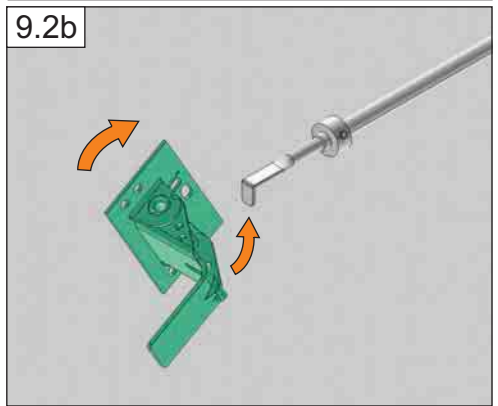
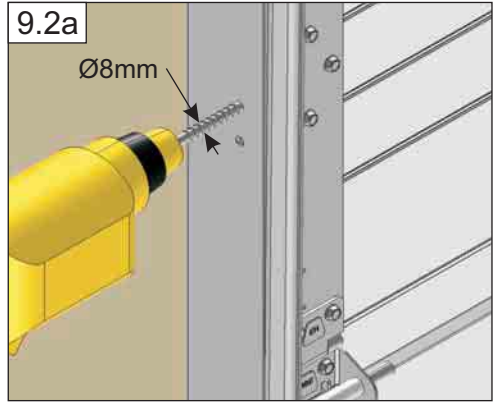
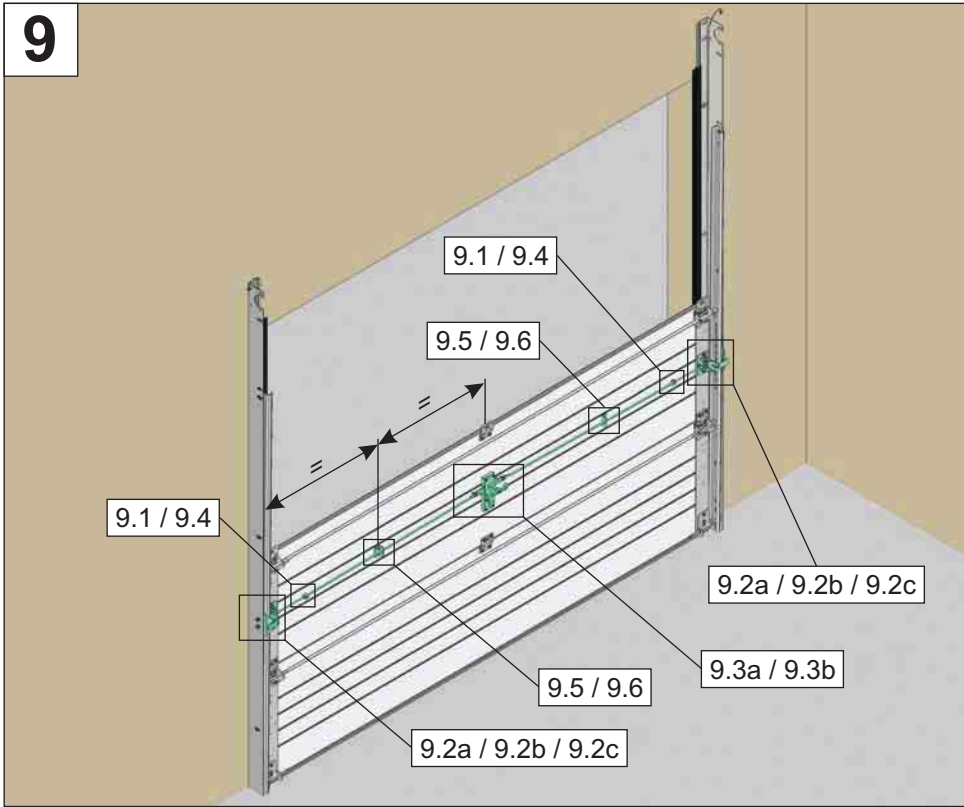

10

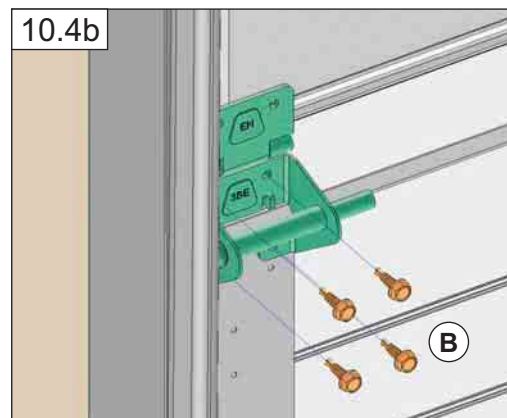
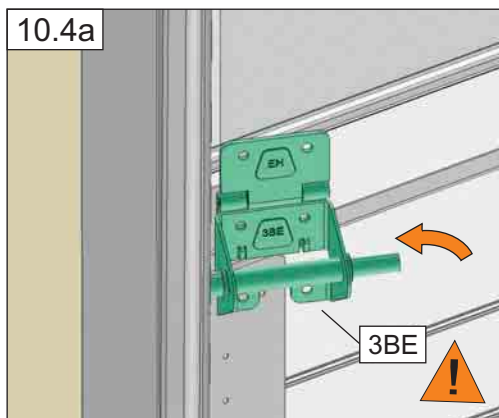
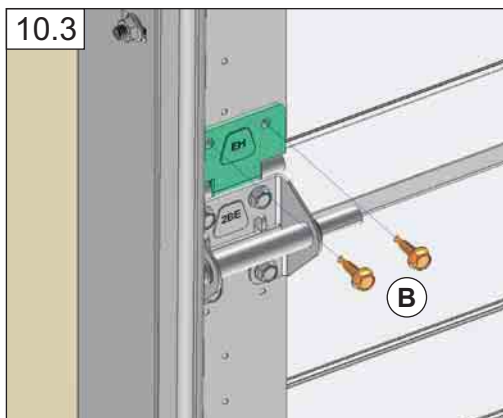
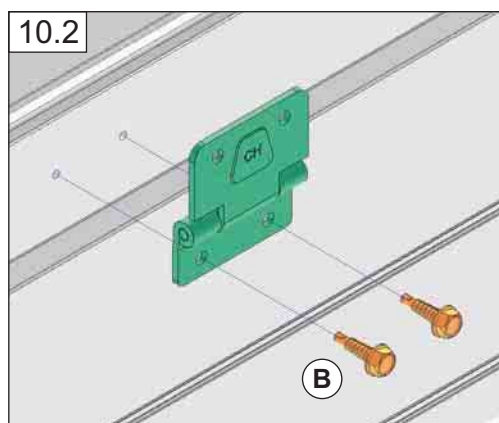
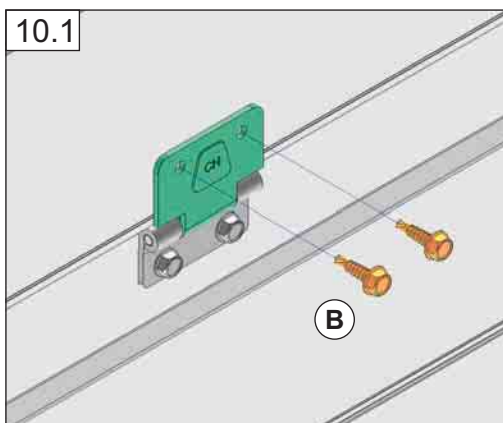
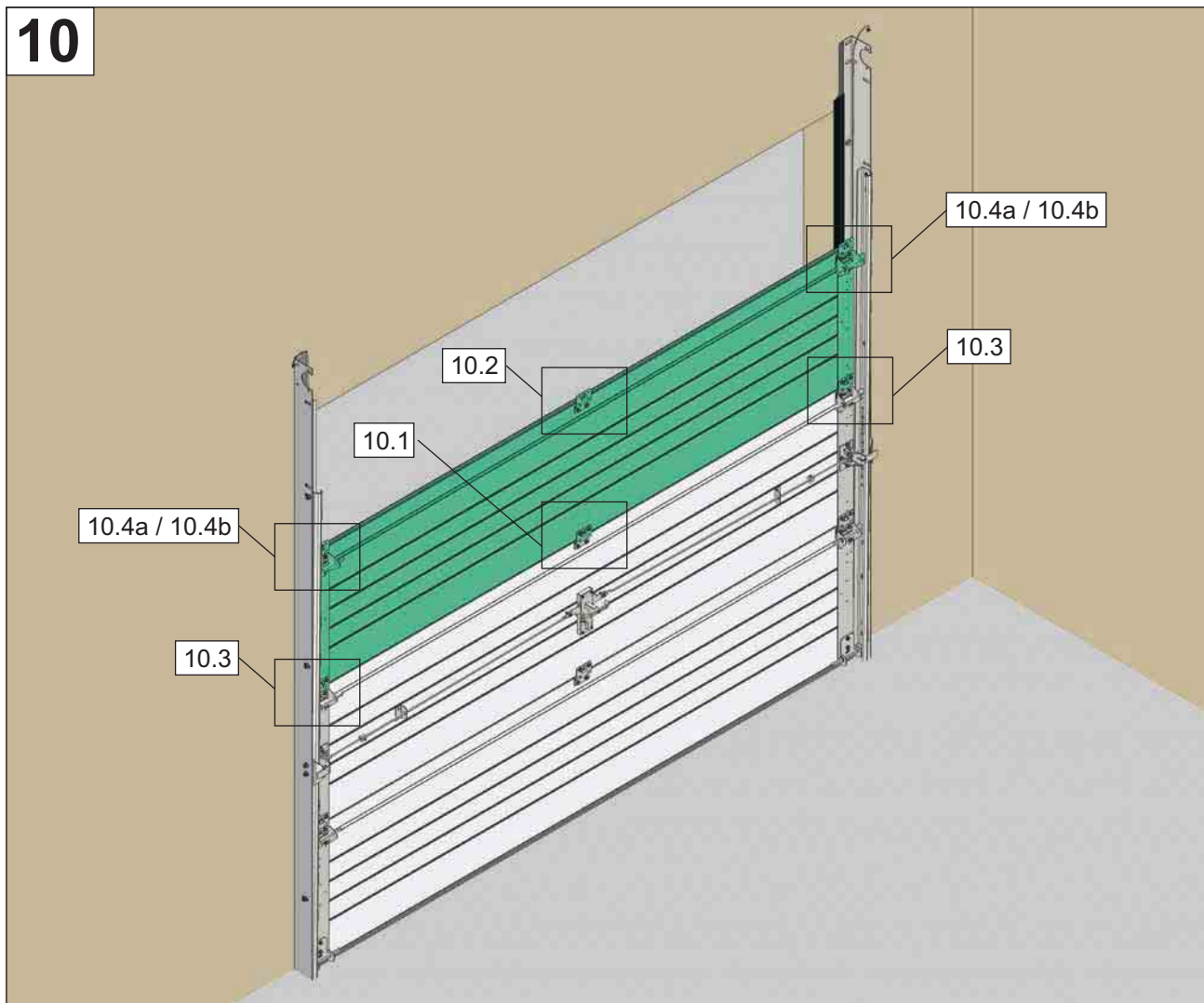

11

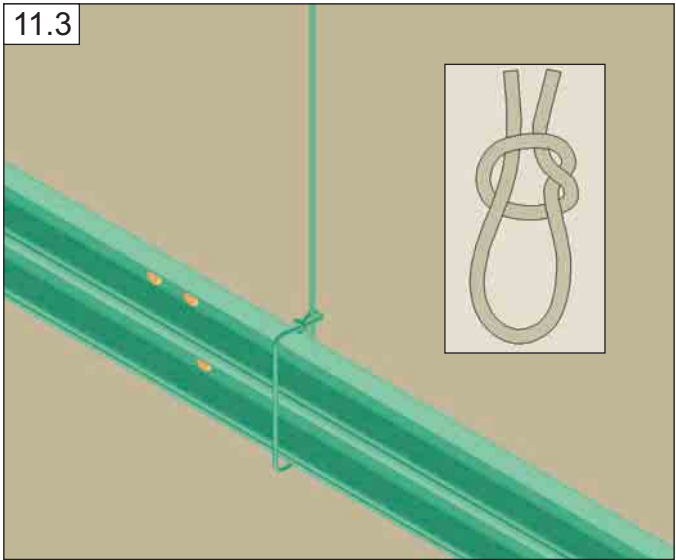
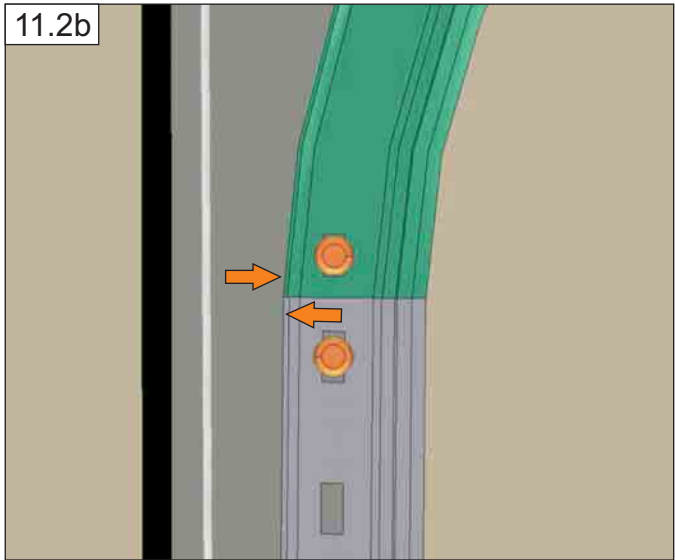
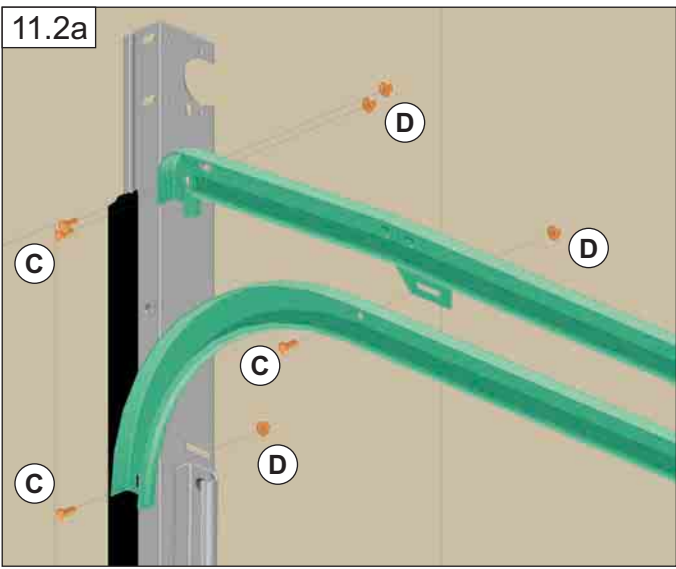
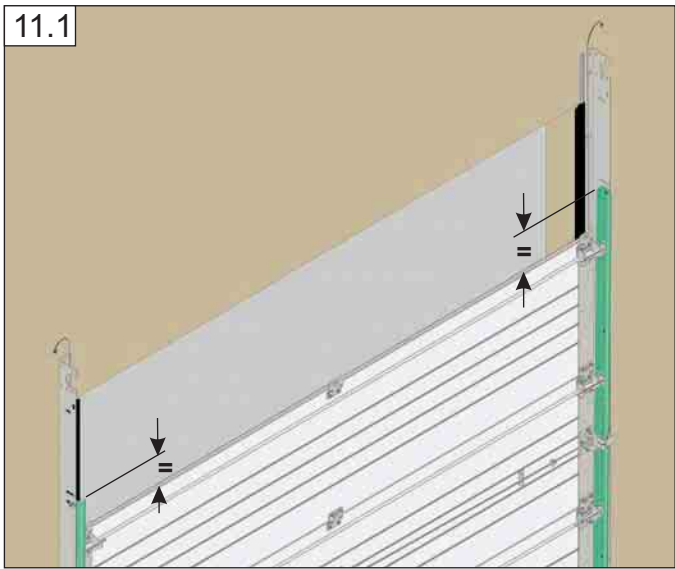
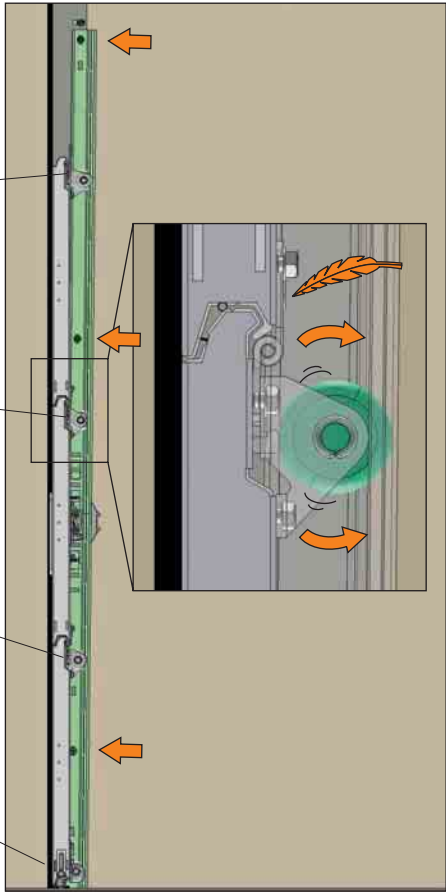
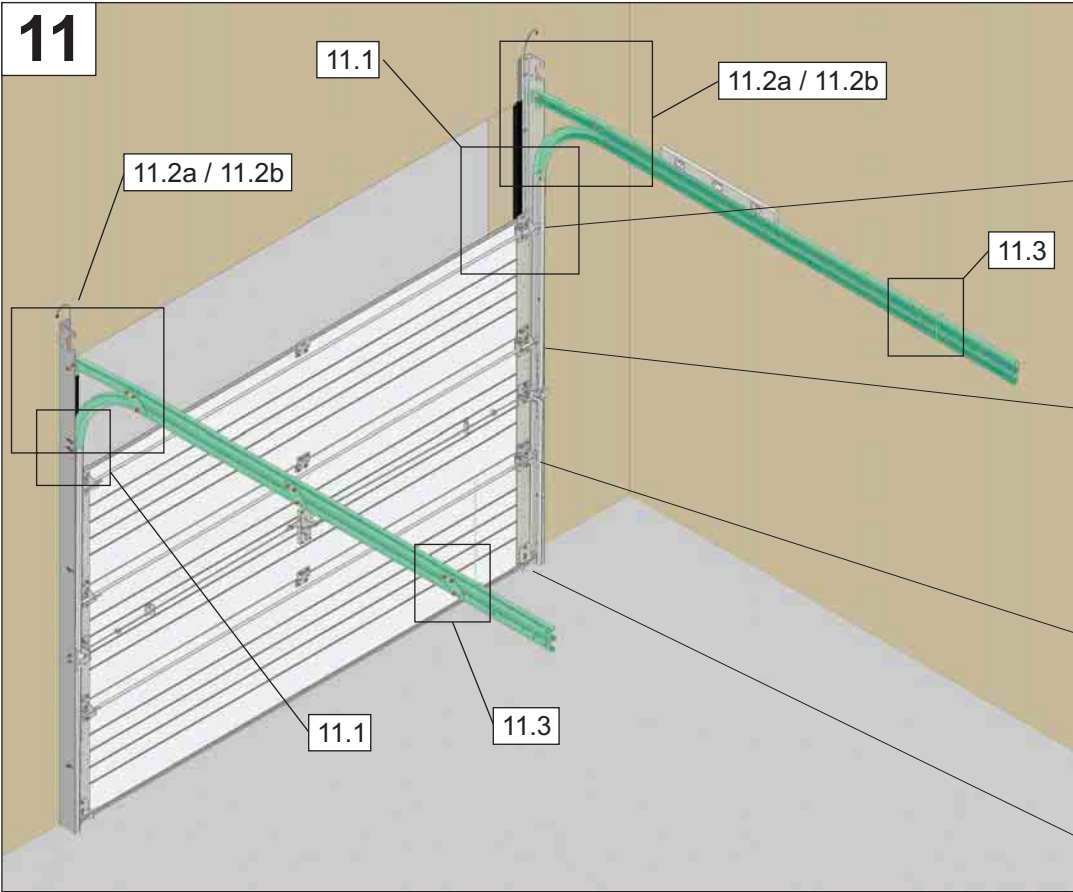

12

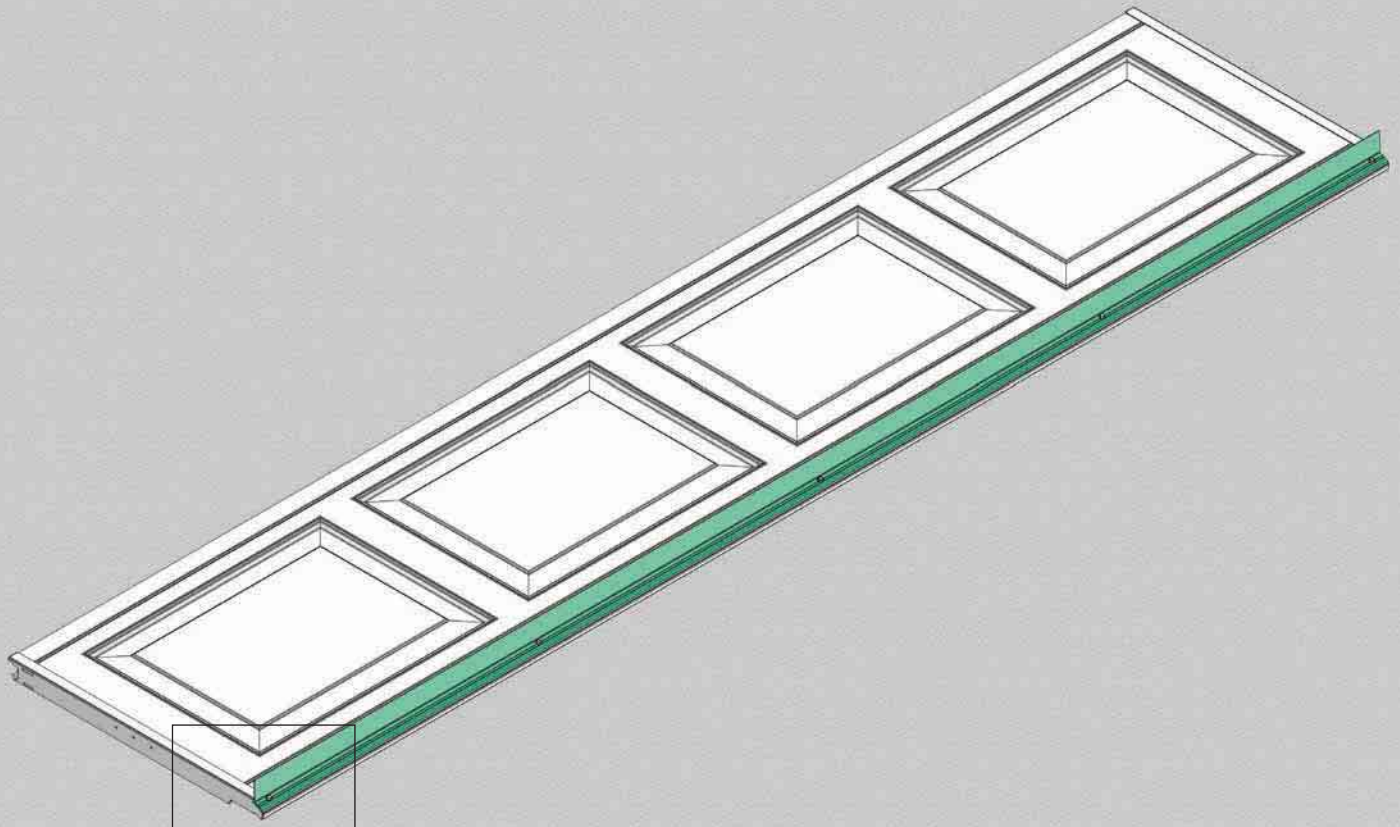

12.1 / 12.2

12.1

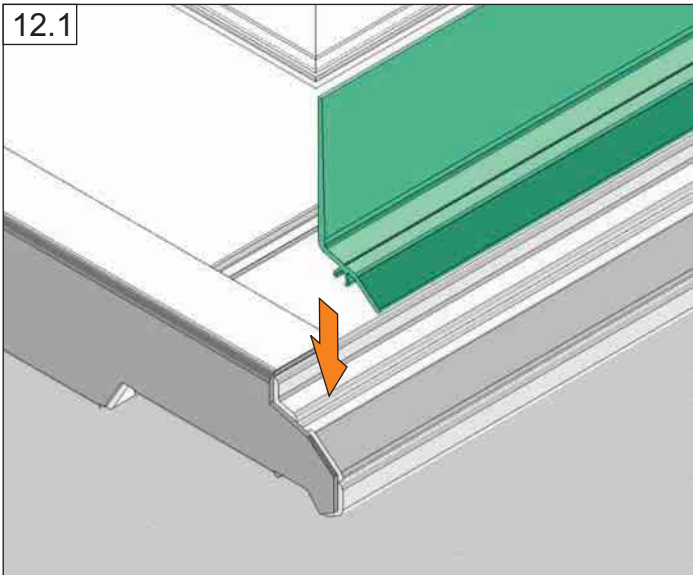

12.2

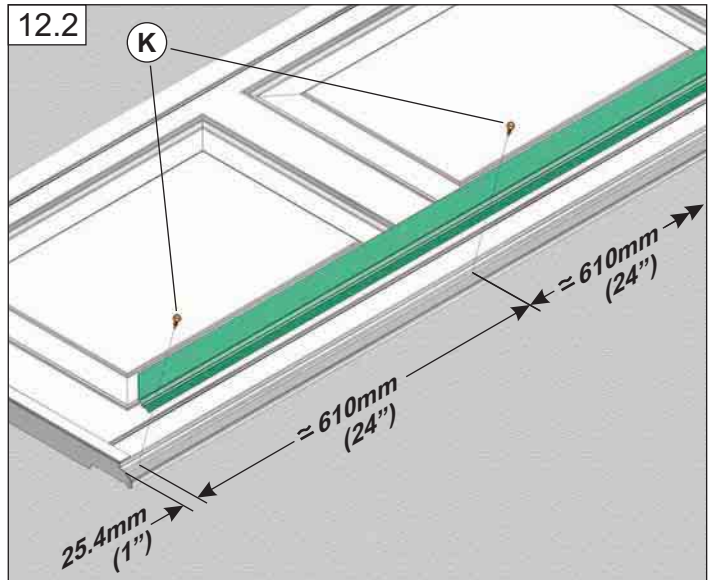

25.4mm
(1")

≈ 610mm
(24")

≈ 610mm
(24")

13

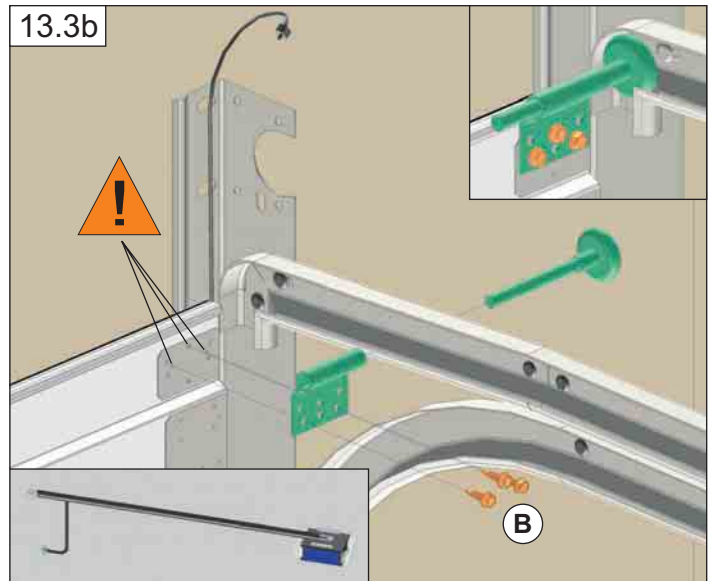
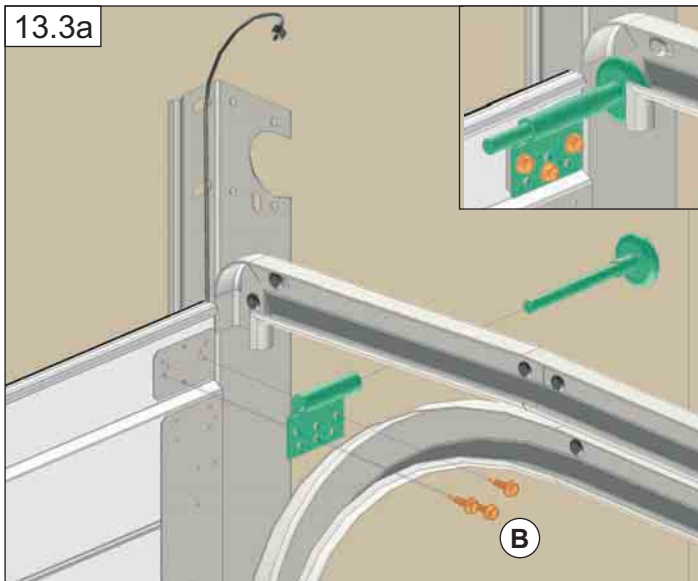
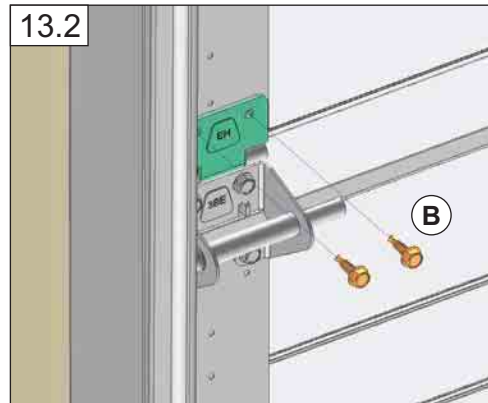
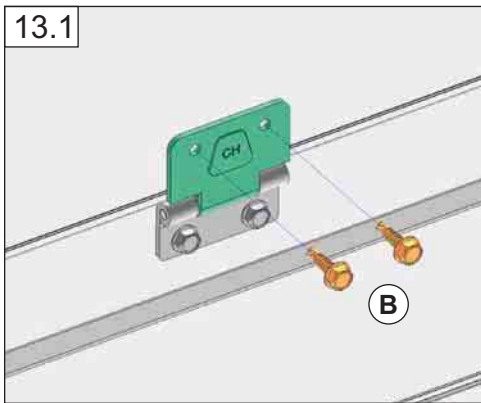
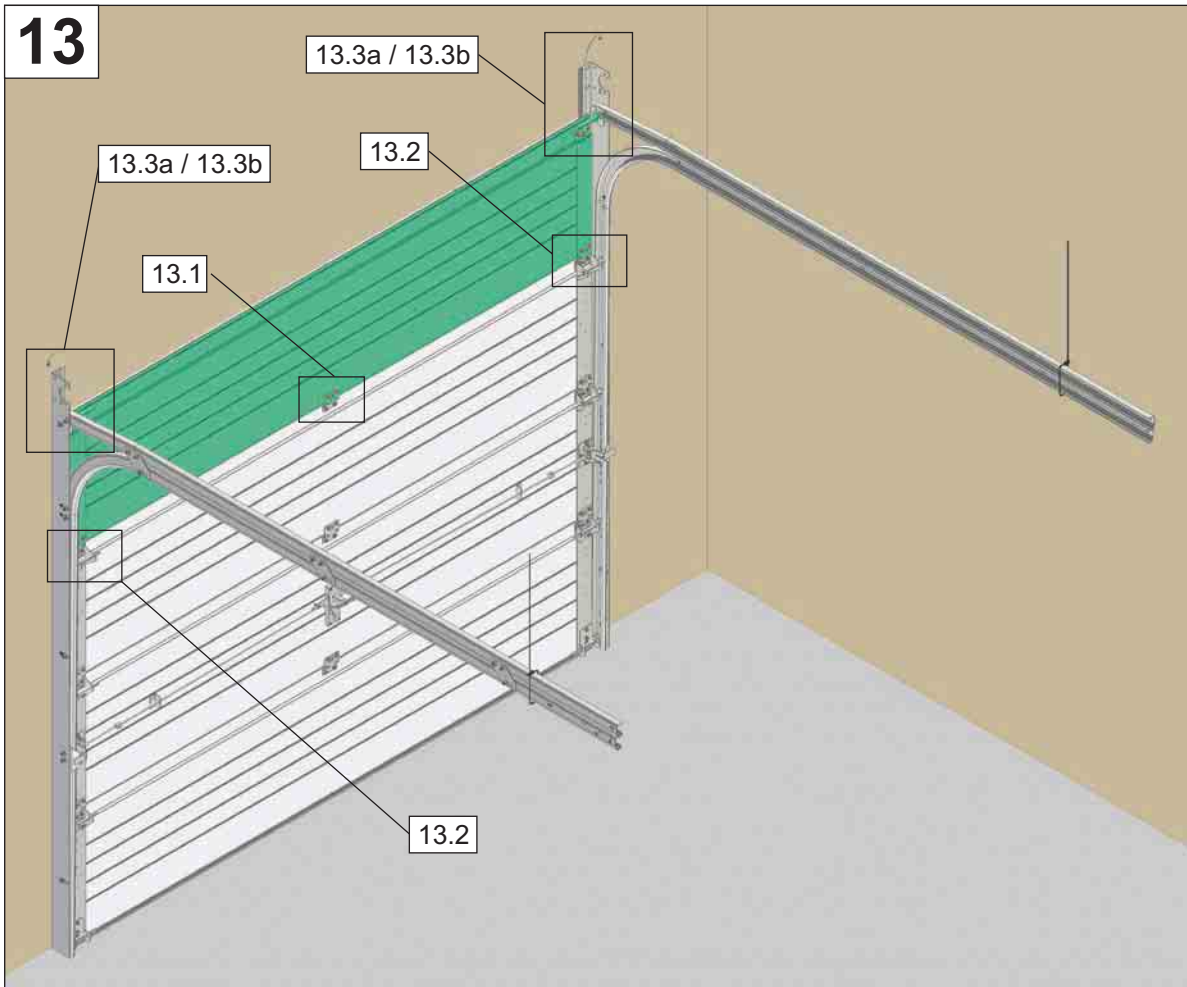

14

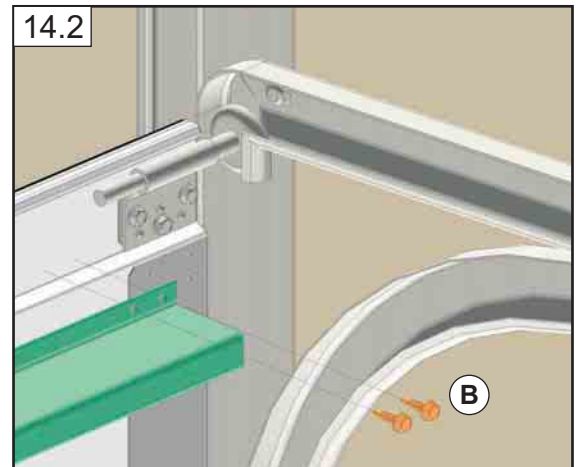
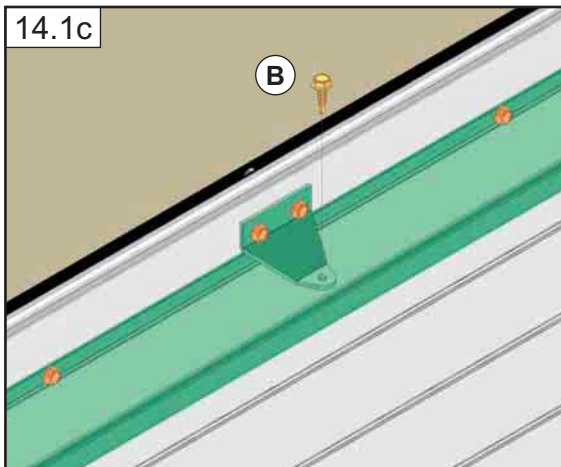
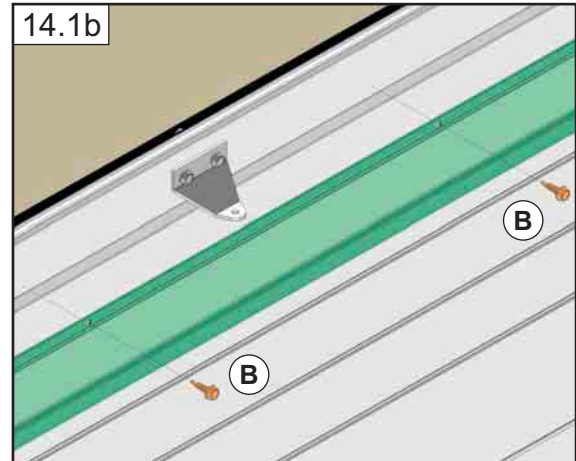
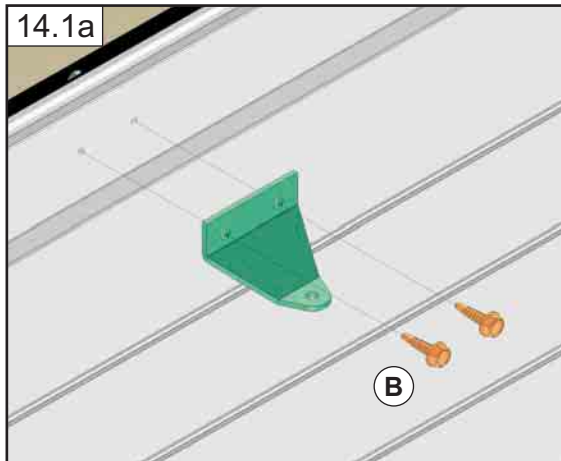
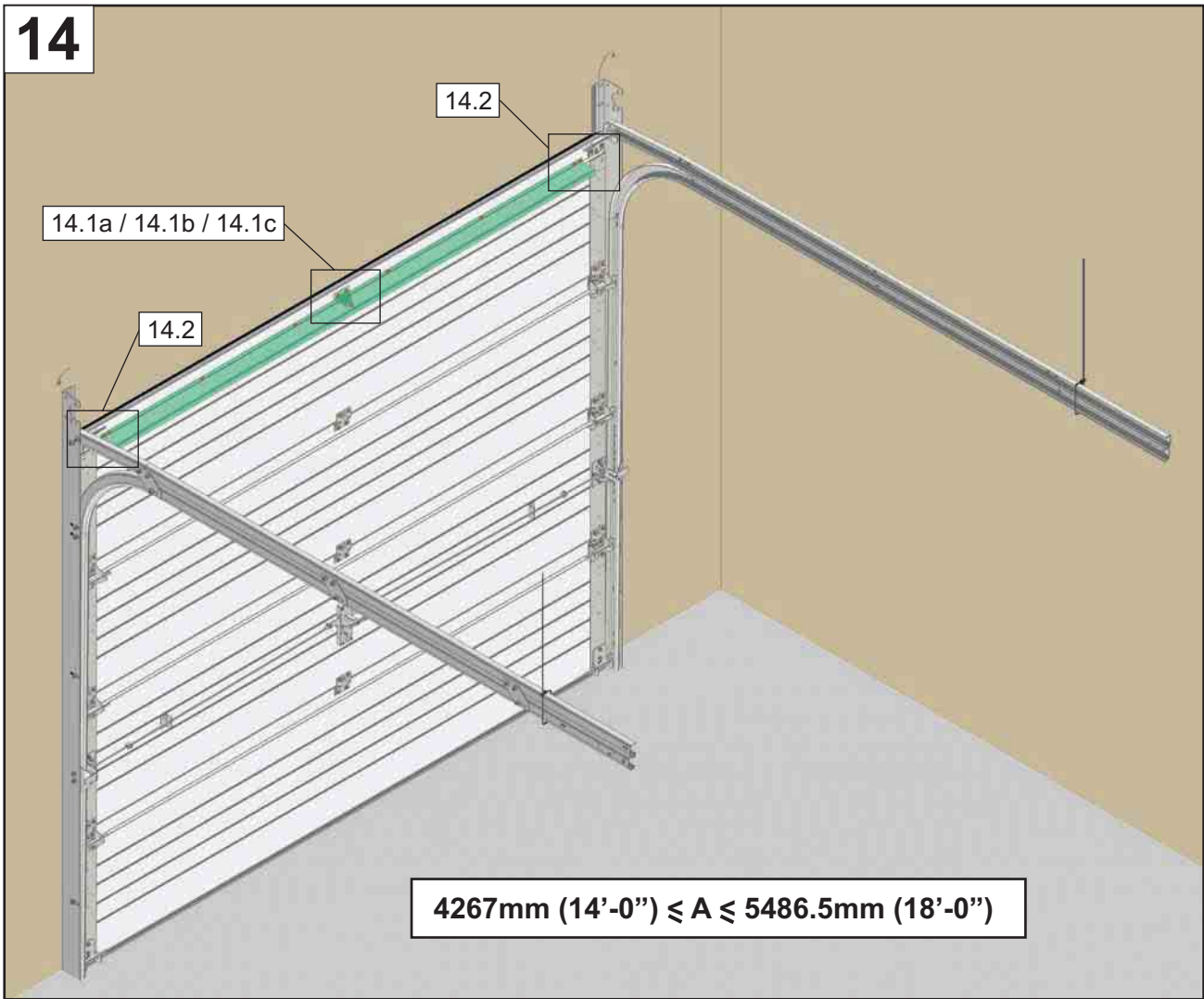

15

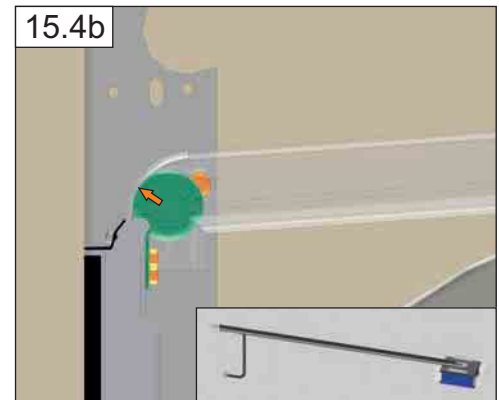
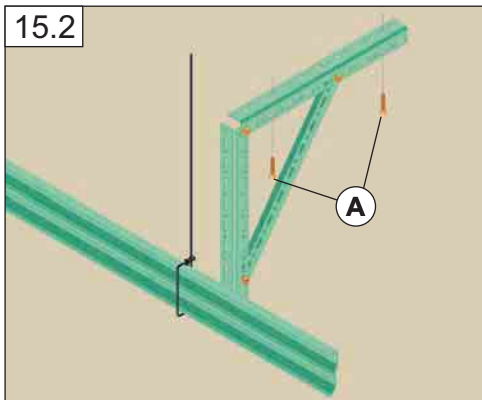
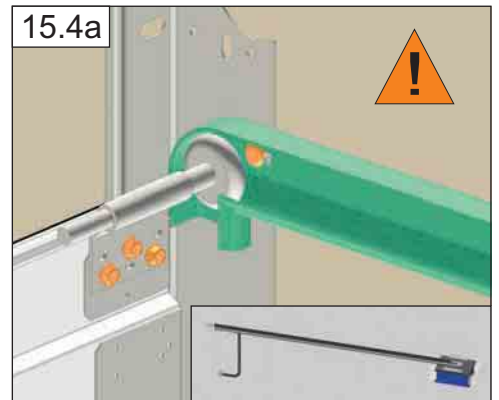
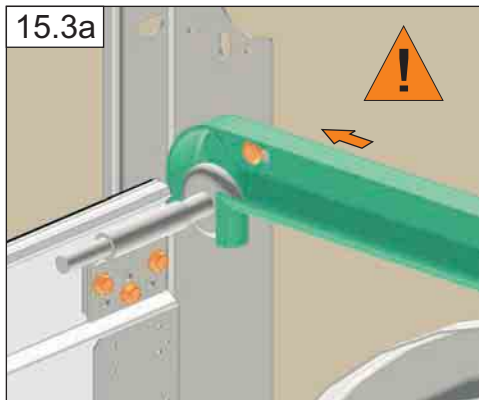
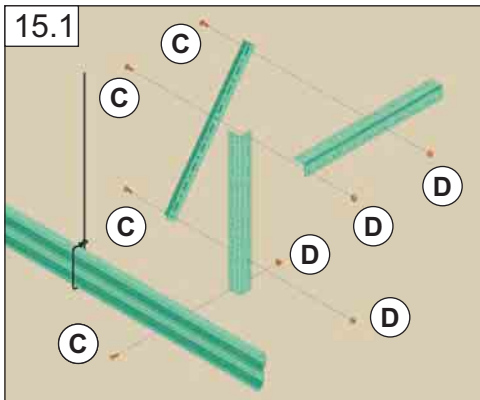
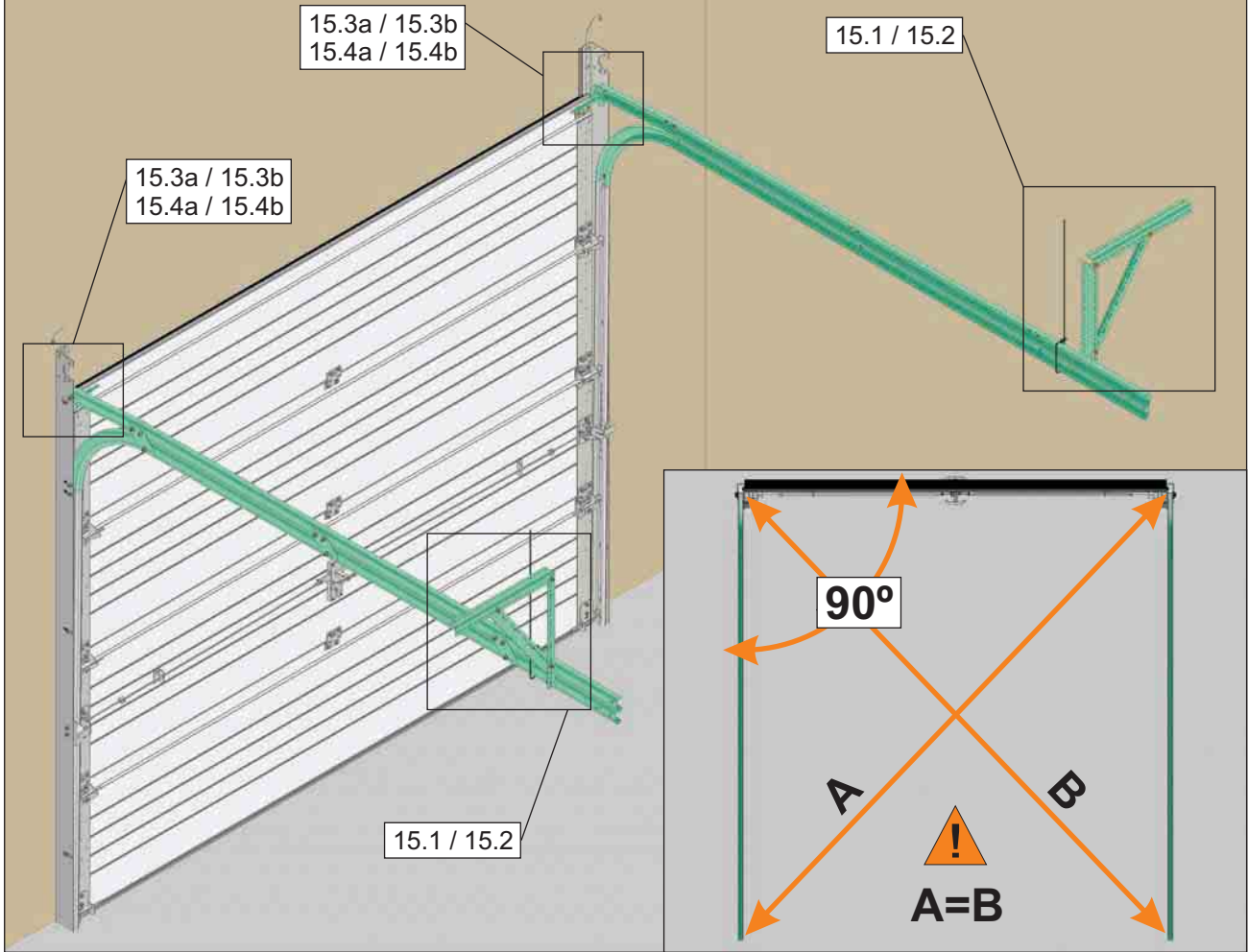

16

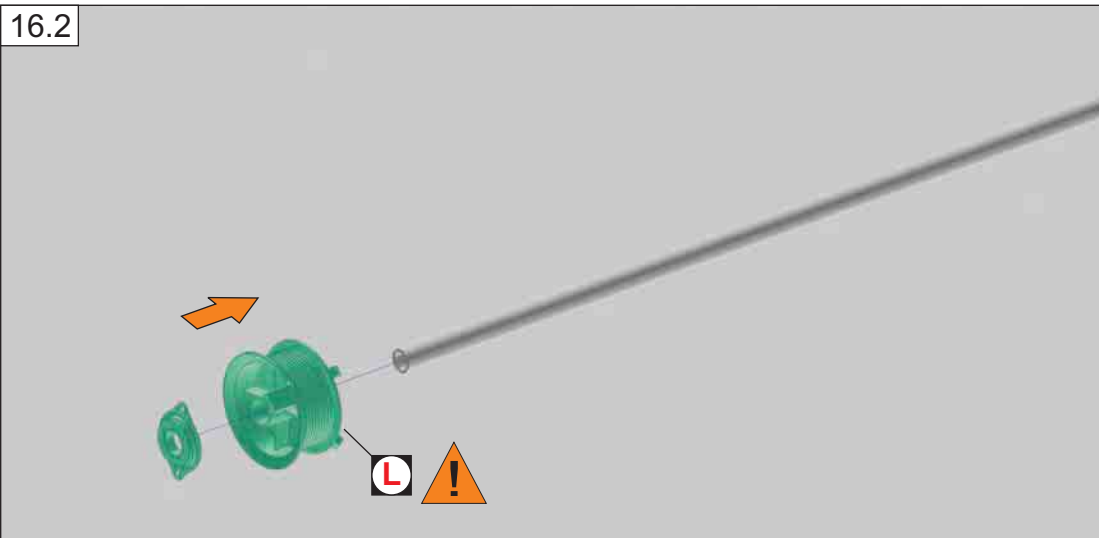
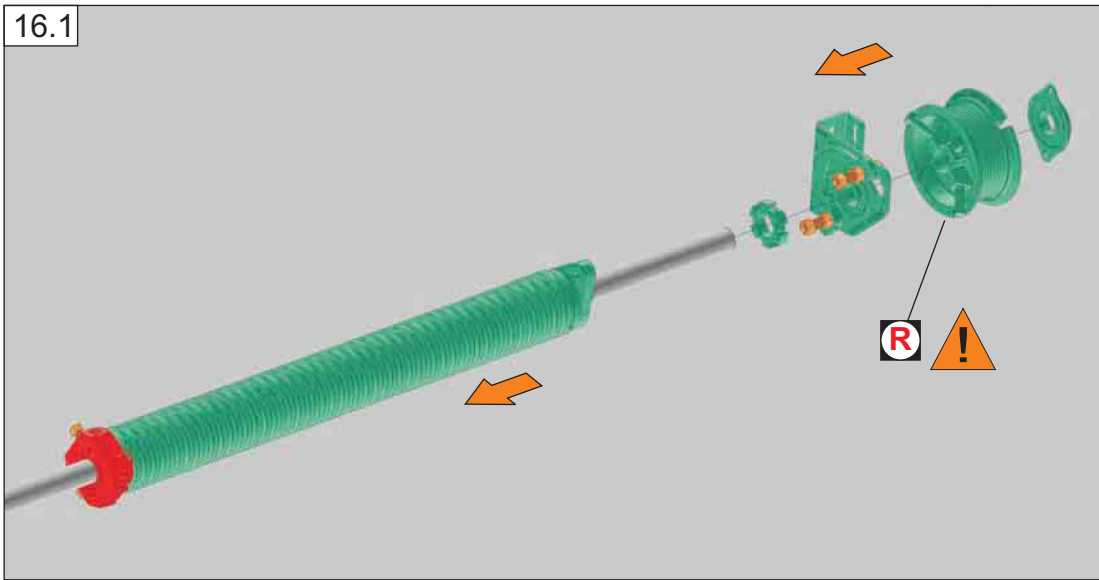
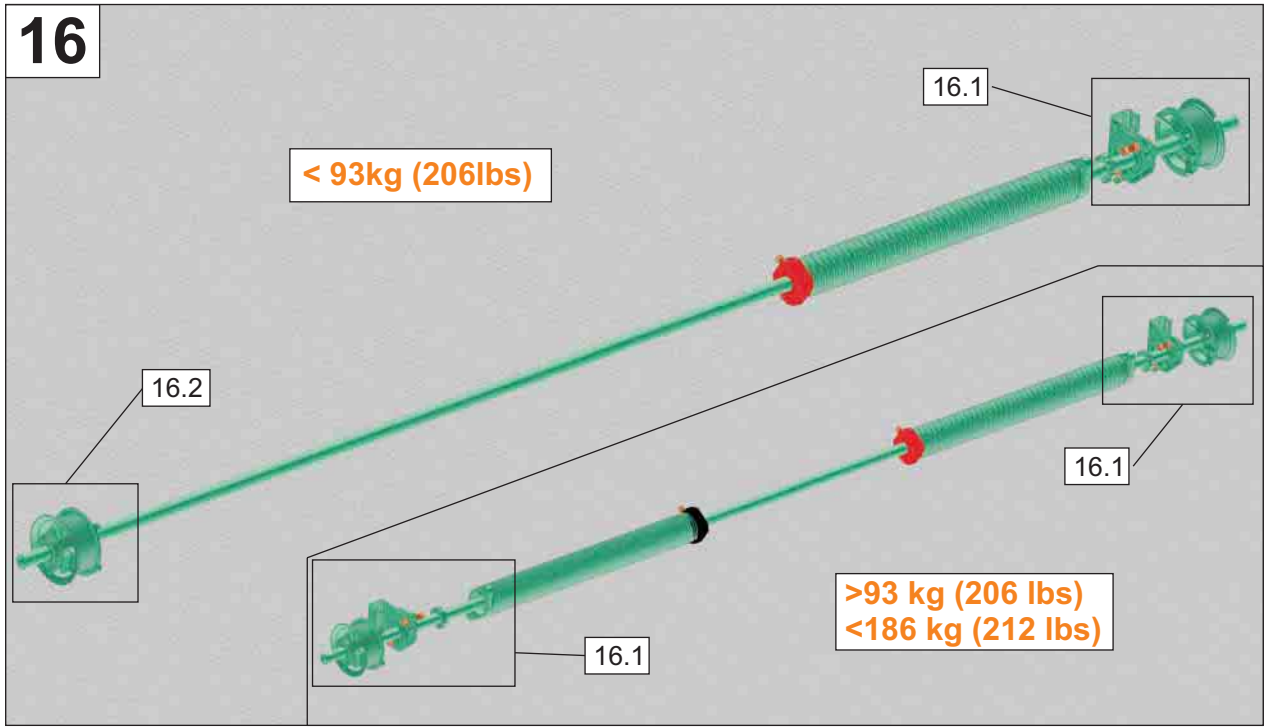

17

17.1 / 17.2 / 17.3 / 17.4 / 17.5 / 17.6
17.7 / 17.8 / 17.9 / 17.10 / 17.11 / 17.12

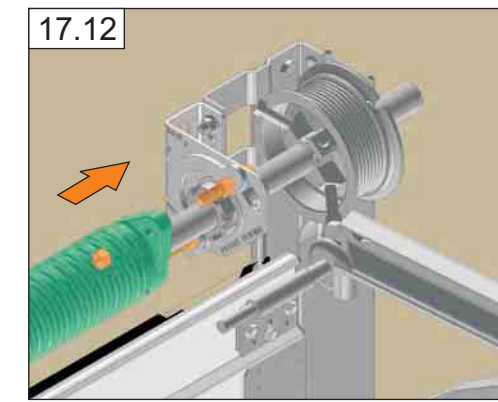
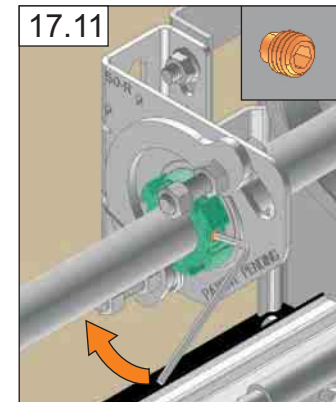
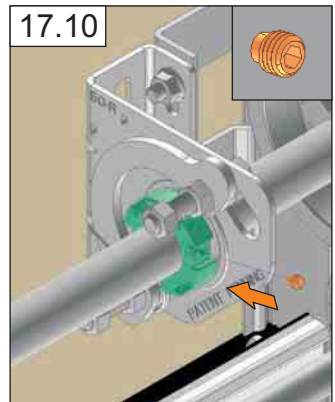
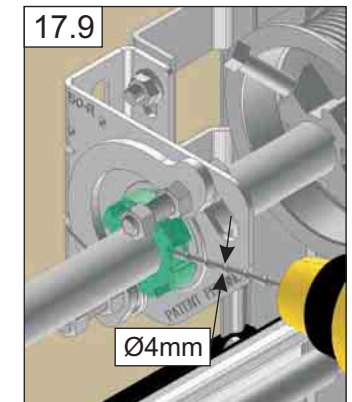
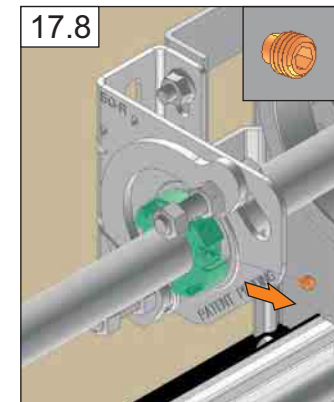
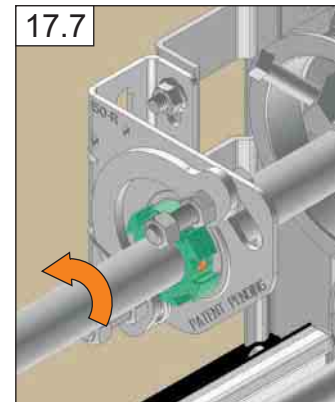
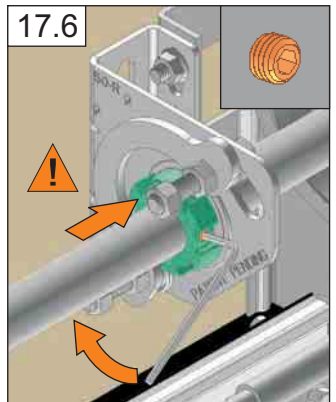
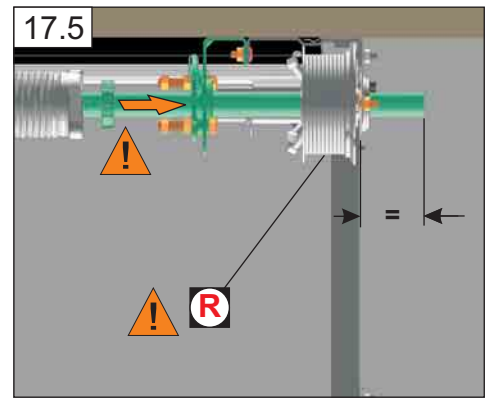
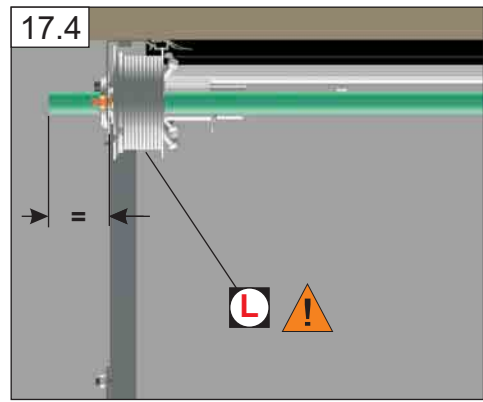
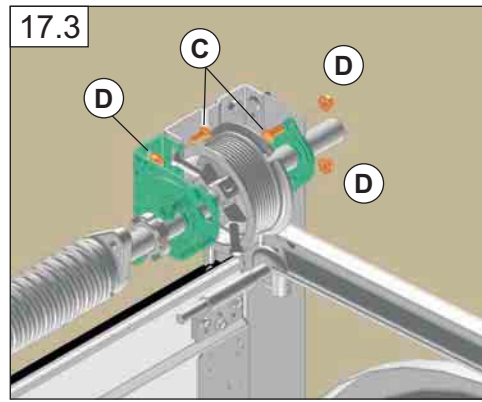
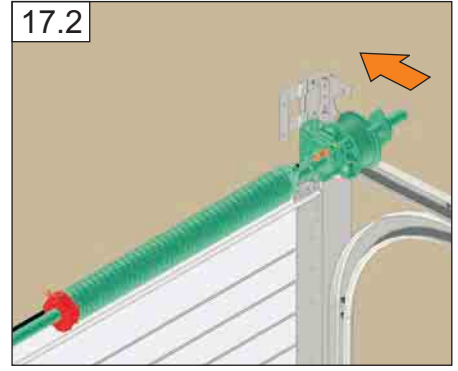
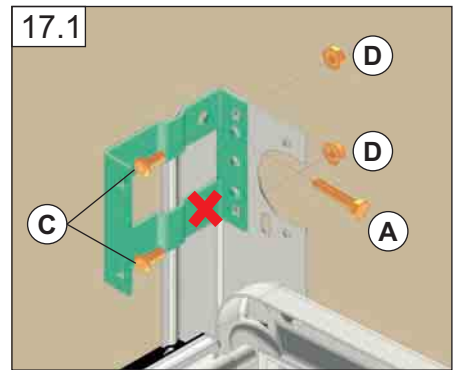
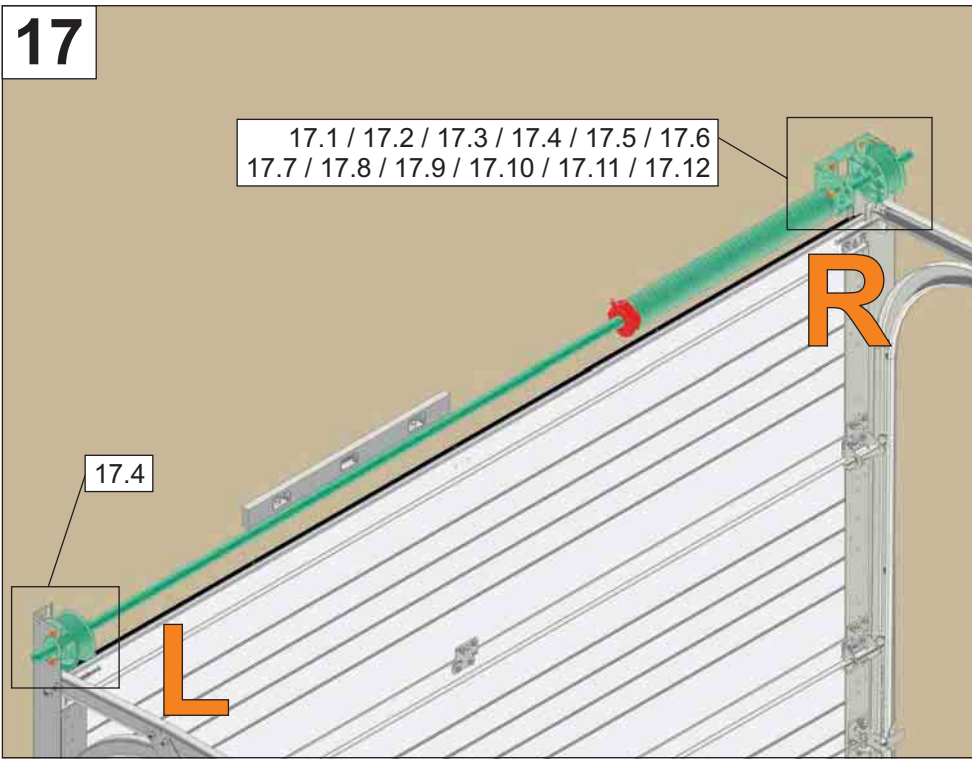

18

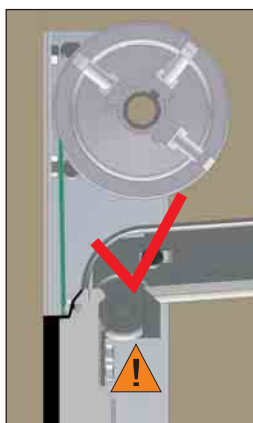
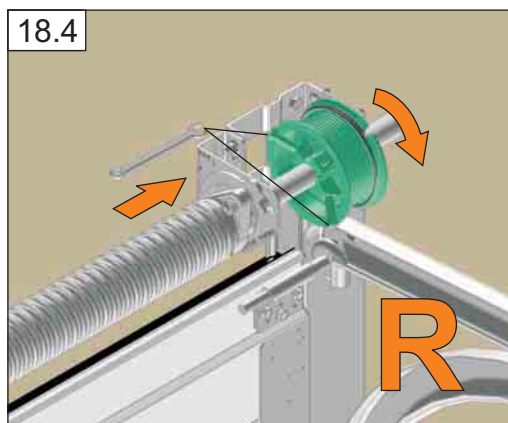
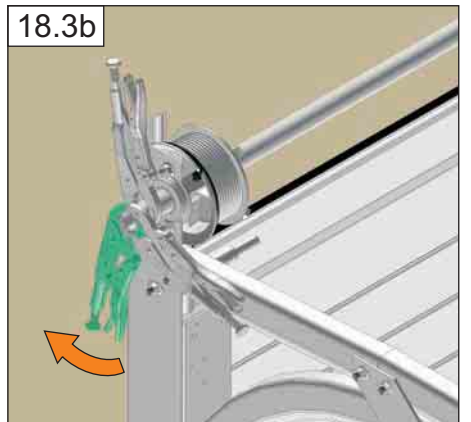
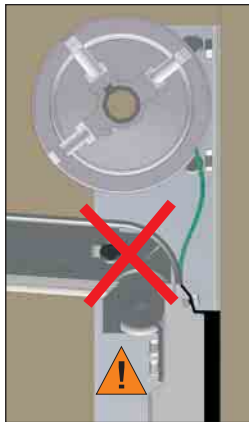
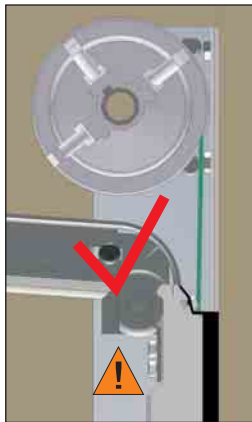
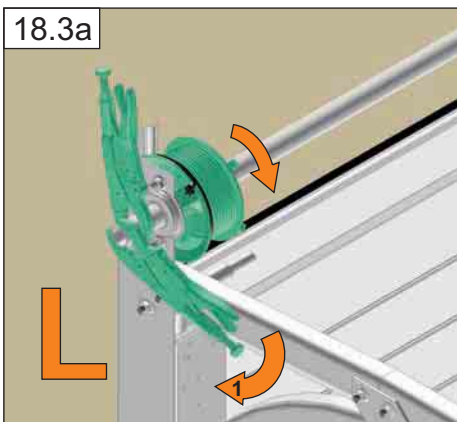
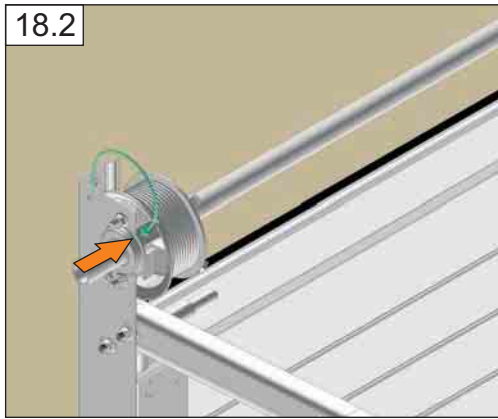
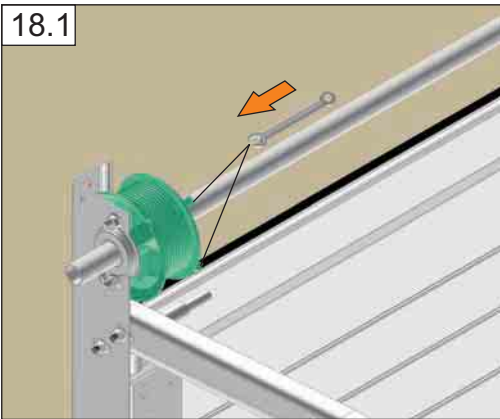
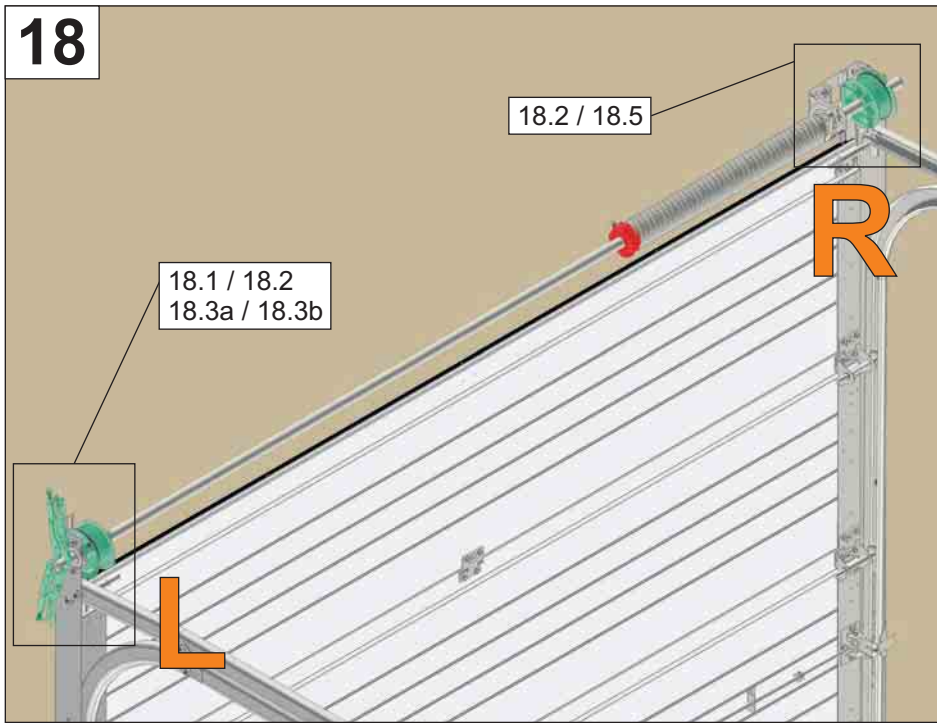

19

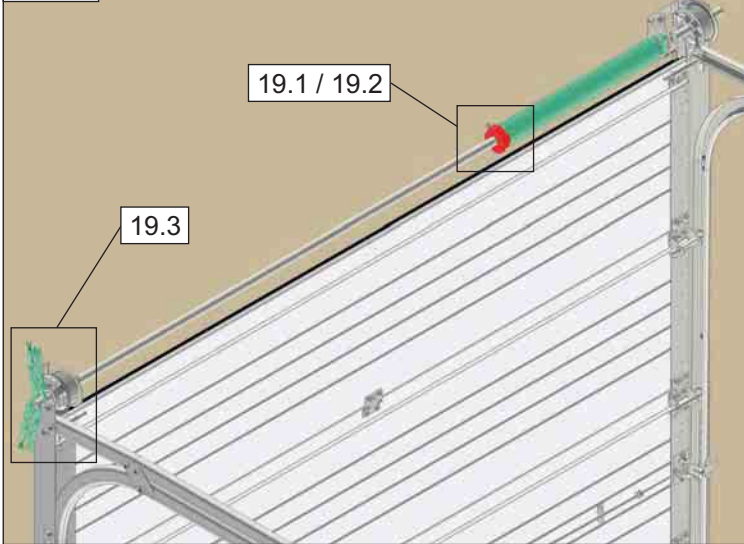

19.1

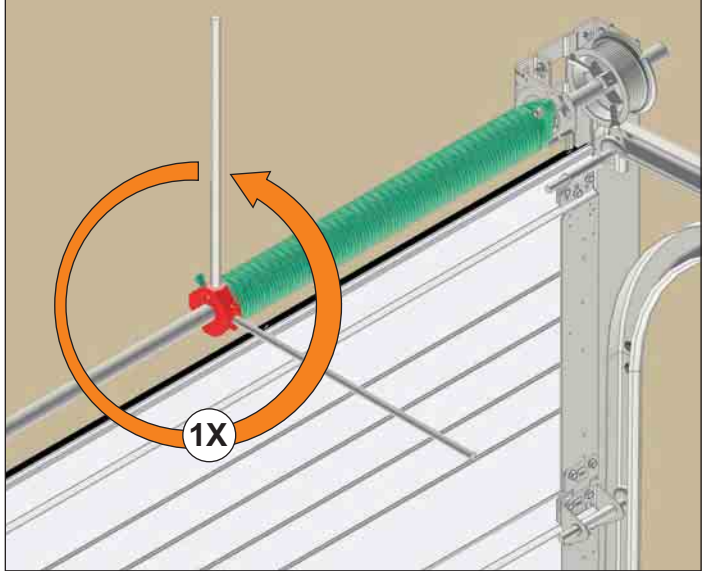

19.2

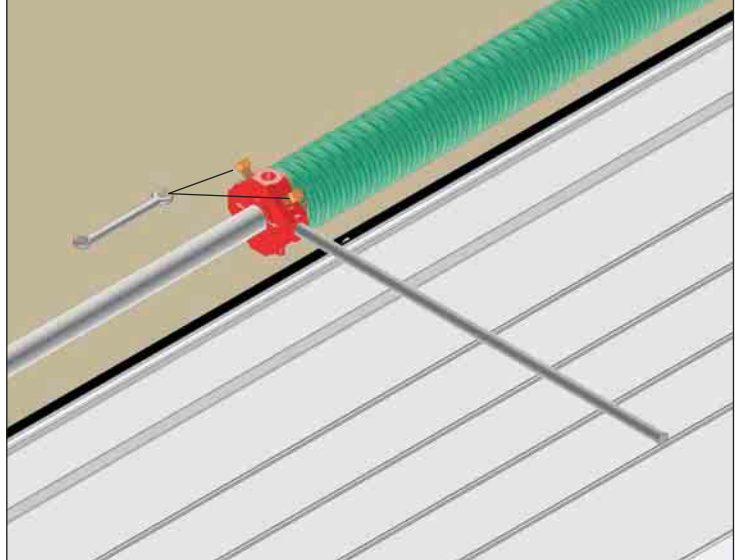

	X
1981mm (6'-6")	6.7
2134mm (7'-0")	7.2
2286mm (7'-6")	7.6
2438mm (8'-0")	8.1
2591mm (8'-6")	8.6
2743mm (9'-0")	9.0
2895mm (9'-6")	9.5
3048mm (10'-0")	9.9

19.3

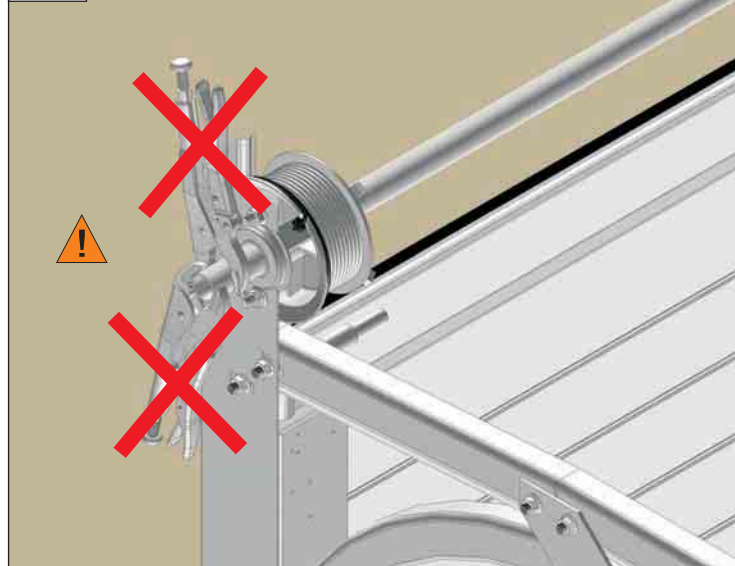

19.4

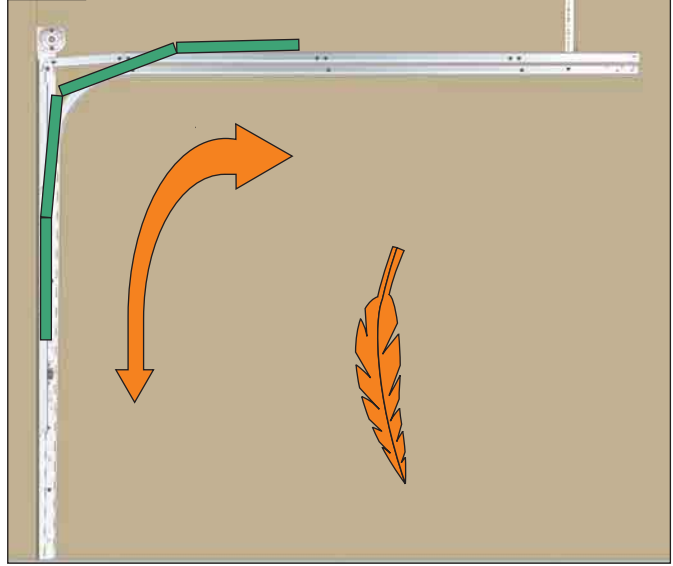

20

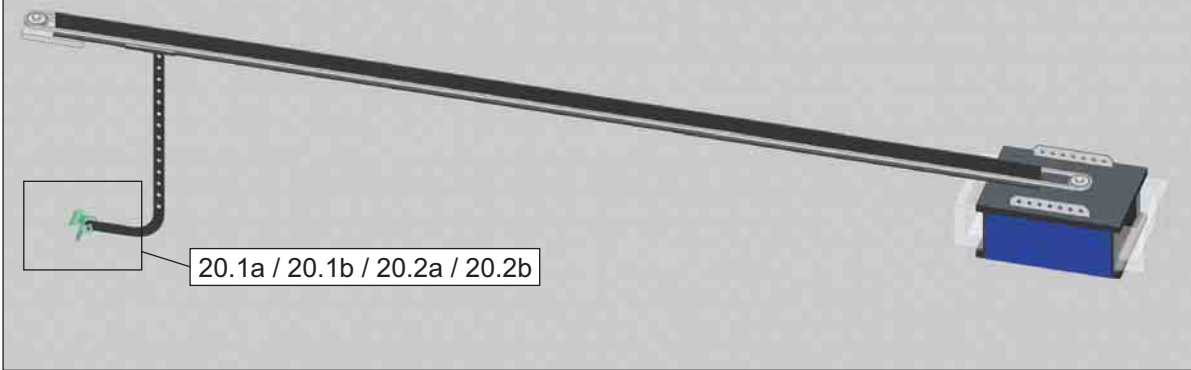

20.1a / 20.1b / 20.2a / 20.2b

20.1a

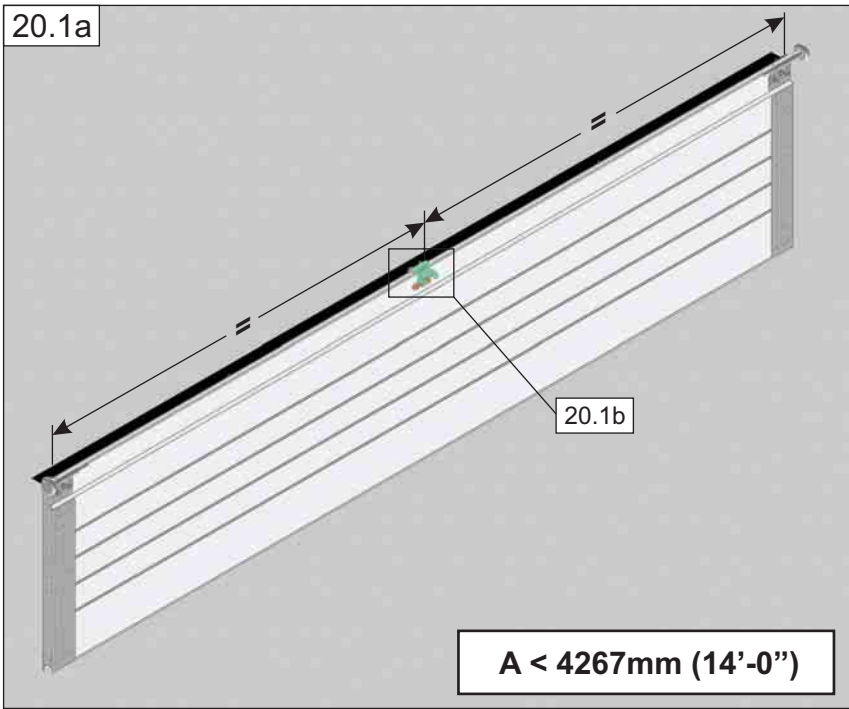

$A < 4267\text{mm (14'-0")}$

20.1b

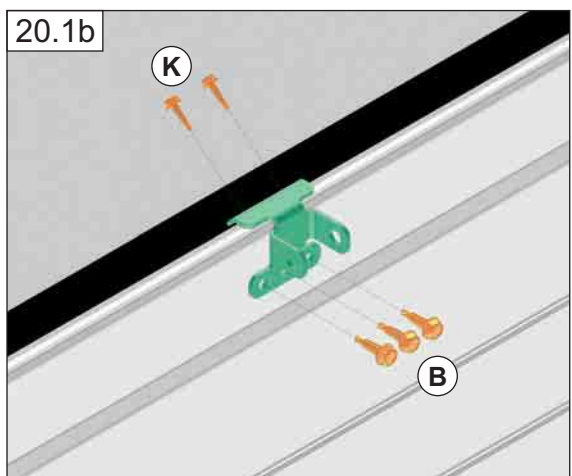

20.2a

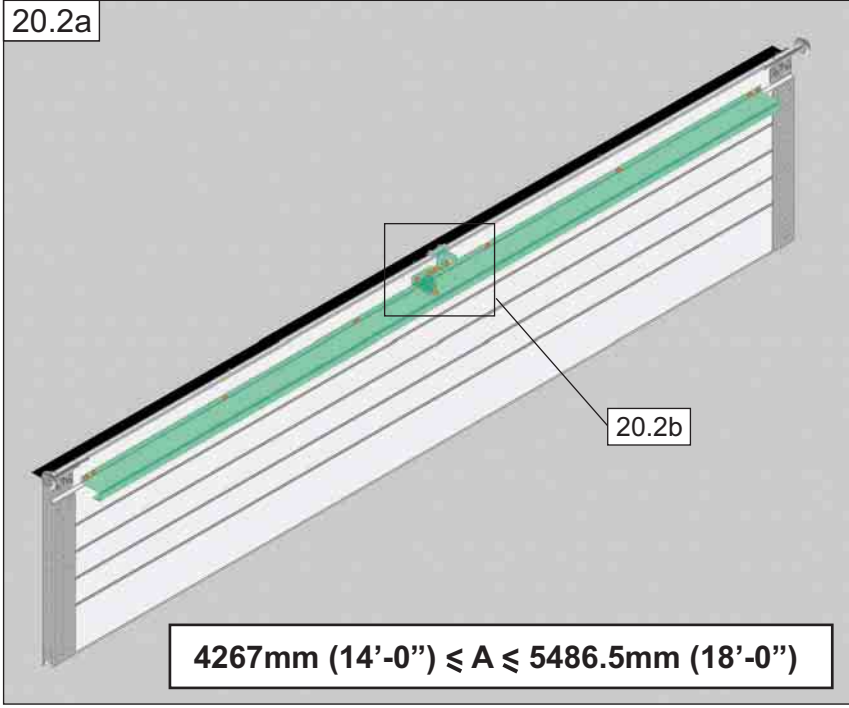

$4267\text{mm (14'-0")} \leq A \leq 5486.5\text{mm (18'-0")}$

20.2b

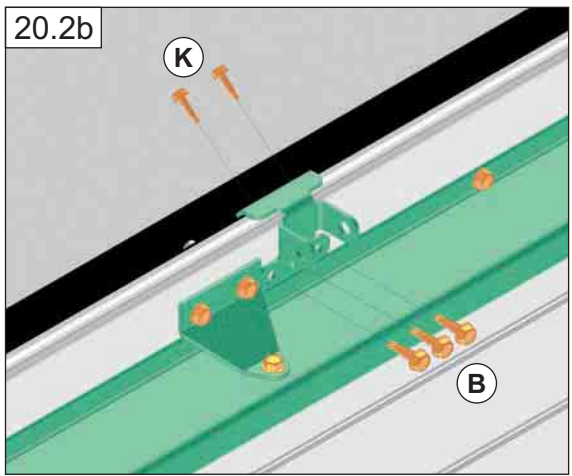

21

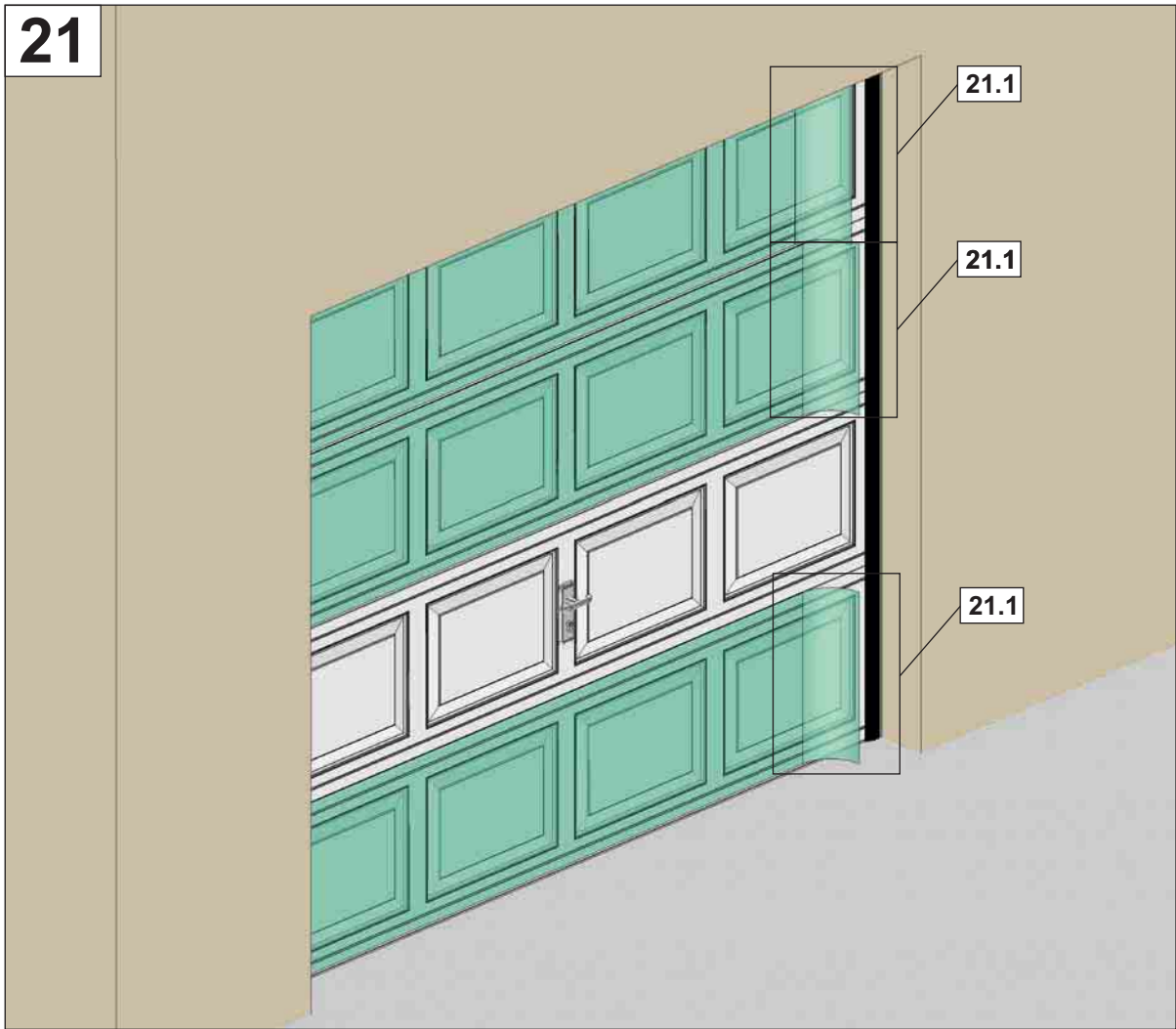

21.1

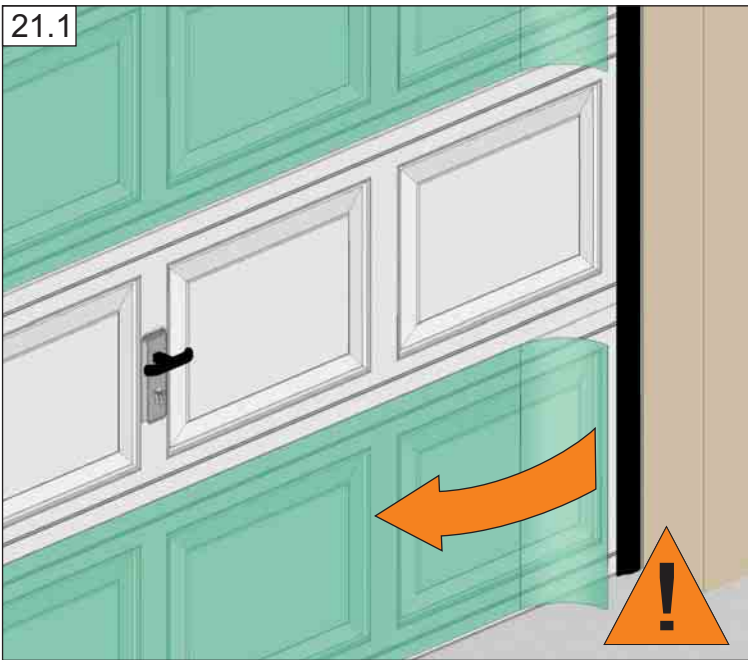

21.2

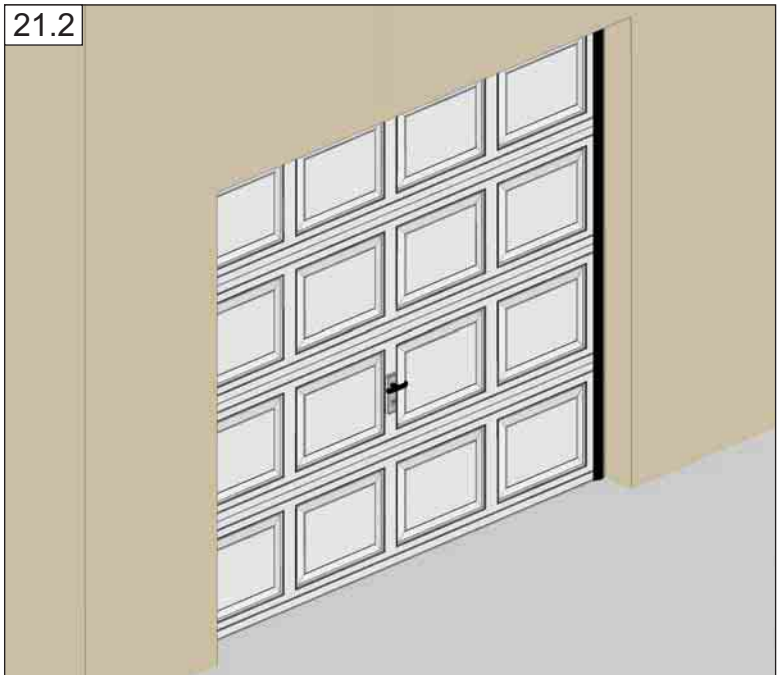

Care & Maintenance

Congratulations on your purchase of a RICHARDS-WILCOX (R-W) Garage Door! With proper care and maintenance, your door will perform reliably for years to come. To maintain your warranty, see the instructions below for when R-W requires performing these maintenance items.

Environment	At Installation	Every 6 Months	Every 12 Months	As Needed
<p>Normal Areas not exposed to salt, salt fog, dirt or other airborne substances, or where winter road salt is not used.</p>		<p>Wash the door and windows with a mild soap (such as car wash soap or dishwashing soap) and water. Wash both interior and exterior. Rinse thoroughly. Do not use harsh or abrasive detergents.</p> <p>Lubricate track and hinges with a silicone or Teflon-based spray. Do not use WD-40® or grease. Then open and close the door to distribute the lubricant.</p>	<p>Inspect springs and hardware for signs of wear. Avoid any contact with the torsion springs as they are under extreme tension. <u>Call your local R-W Dealer to schedule a service call if you suspect any problems.</u></p>	<p>If surface rust appears, immediately contact your local R-W Dealer for inspection and repair options.</p>
<p>Winter Areas where winter road salt is used.</p>		<p>Wash the door and windows. See above.</p> <p>Lubricate track and hinges. See above.</p>	<p>Inspect springs and hardware for signs of wear. See above.</p>	<p>Clean off road salt from interior and exterior surfaces. Use a mild soap (such as car wash soap or dishwashing soap) and water. Rinse thoroughly. Do not use harsh or abrasive detergents.</p> <p>If surface rust appears, immediately contact your local R-W Dealer for inspection and repair options.</p>
<p>Coastal Areas with exposure to salt or salt fog.</p> <p>Harsh Areas with exposure to dirt or other airborne substances.</p>	<p>Apply a good quality car wax to the door immediately after installation, unless you are going to paint the door (see accompanying painting instructions). Follow car wax application instructions.</p>	<p>Wash the door and windows. See above.</p> <p>Wax the door. See "At Installation."</p> <p>Lubricate track and hinges. See above.</p>	<p>Inspect springs and hardware for signs of wear. See above.</p>	<p>Wash the door and windows with a mild soap (such as car wash soap or dishwashing soap) and water. Wash both interior and exterior. Rinse thoroughly. Do not use harsh detergents.</p> <p>If surface rust appears, immediately contact your local R-W Dealer for inspection and repair options.</p>

WARNING - Garage door springs, cables, brackets and other hardware attached to the springs are under very high tension and, if handled improperly, can cause serious injury. Only an authorized R-W Dealer should adjust them. Do not attempt to repair yourself.

Painting Instructions

All RICHARDS-WILCOX (R-W) residential steel garage doors are already painted with a baked-on finish. No additional painting is required. If you want to apply another color, however, the following steps are required. NOTE: Only paint the exterior of the door while it is in the closed position.

1. Use the following solution, with a soft bristle brush, to remove mildew and other surface contaminants: 1 cup household detergent + 5 gallons warm water
2. Rinse thoroughly with water.
3. Use a powder cleanser, diluted with water, with a soft bristle brush, to prepare the surface for better paint adhesion. Do not use sandpaper, deglossers, or liquid sandpaper to prepare the door surface.
4. Rinse thoroughly with water and allow to dry.
5. Use a high quality acrylic latex exterior paint. Apply according to manufacturer's instructions. Do not use oil-based paint or any "rust-inhibitive" paint. Do not paint in direct sunlight or when surface is warm to the touch. Lap marks will result. Brush application is recommended.
6. Avoid getting paint on any gasket seals between door sections. Not all R-W doors have these gasket seals.

IMPORTANT: Since R-W has no control over recoating, we do not warrant this product against peeling of the original factory-applied baked-on finish or subsequent coats of paint where recoating has occurred.

Anstrich-Anweisungen für Garagen-Tore

Alle RICHARDS-WILCOX (R-W) privat Garagen-Tore aus Stahl werden bereits mit einer Kunststoff-Endschicht ausgestattet. Kein zusätzlicher Anstrich ist erforderlich. Wenn Sie jedoch eine andere Farbe anwenden möchten sind die folgenden Schritte notwendig.

ANMERKUNG: Malen Sie nur das Äußere des Tores, während es in der geschlossenen Position ist.

1. Benutzen Sie die folgende Lösung, mit einer weichen Borste, um Mehltau und andere Oberflächenverunreiniger zu entfernen: 1/2 Tasse Haushalt Reinigungsmittel + 10 Liter warmes Wasser
2. Spülen gänzlich mit Wasser.
3. Benutzen Sie einen trockenen Pulverreiniger, der mit Wasser gelöst wird und mit einer weichen Borste aufgebracht wird, um die Oberfläche auf eine bessere Farbe-Adhesion vorzubereiten. Benutzen Sie kein Sandpapier, Entglänzer oder flüssiges Sandpapier, um die Toroberfläche vorzubereiten.
4. Spülen Sie gänzlich mit Wasser und lassen Sie trocknen.
5. Benutzen Sie eine hohe Qualitäts-Acryllatexfarbe für Außenanwendung. Folgen Sie den entsprechenden Anweisungen des Farbeherstellers an. Benutzen Sie keine Ölfarbe oder irgendeine korrosionshemmende Farbe. Malen Sie nicht in der direkten Sonne oder wenn die Oberfläche warm ist. Überlappungsspuren resultieren. Borste-Anwendung wird empfohlen.
6. Vermeiden Sie Farbe auf der Gummimitteldichtung zwischen den einzelnen Torgliedern. Nicht alle R-W Tore sind mit diesen Dichtungen ausgestattet.

WICHTIG: Da R-W keinen Einfluss auf diese hinzugefügte Farb-Endschicht hat, gewährleisten wir dieses Produkt nicht gegen eine abgeblätterte Endschicht, die bei R-W in der Fabrik angewendet worden war oder gegen nachfolgenden Farb-Endschichten.